

Angetriebene Seilwinden

Driven rope winches

Treuil à câble entraîné

- Lastbereich 100 kg - 50 t
- Elektroseilwinden
- Hydraulische Seilwinden
- Pneumatische Seilwinden

Auf Ihren Einsatzfall abgestimmt:

- Seilkapazität
- gerillte Seiltrommel
- auskuppelbare Seiltrommel
- geteilte Seiltrommel
- Seileinweiser oder Seilanpreßrolle
- Seilgeschwindigkeiten
- einfache Handbedienung bis zu komplexen Steuerungen
- Sonderausstattung wie Hubbegrenzung, Überlastschalter oder Schlaffeilschalter
- Für speziellen Einsatz z. B. BGV C1 oder Seeschiffe
- erhöhte Anforderungen an Staub- und Spritzwasserschutz

- Lifting capacity 100 kg - 50 t
- Electric rope winches
- Hydraulic rope winches
- Pneumatic rope winches

Adapted to your requirements:

- Rope capacity
- grooved drum
- Disengager / clutch
- devided rope drum
- Rope guide or rope pressure-pad
- Rope speed
- simple hand operation or complex control systems
- additional accessories like limiting switch, overload protection or slack rope switch
- For special application (e.g. for stages and studios) or marine application
- better dust-proof and weatherproof protection

Bitte Gesamtkatalog anfordern oder downloaden!

Please order our comprehensive program brochure or download!

Demandez notre catalogue détaillé " Treuil à câble entraîné " ou faites le téléchargement !



- Capacité de levage 100 kg - 50 t
- Treuils électriques
- Treuils hydrauliques
- Treuils pneumatiques

Adapté à votre emploi :

- Résistance du câble
- Tambour à câble rainuré
- Tambour débrayable
- Tambour divisé
- Guidage de câble ou rouleau presse câble
- Vitesse du câble
- Commande manuelle ou commande complexe
- Options telles que limiteur en fin de course, limiteur de charge ou interrupteur de mou de câble
- Pour utilisations particulières, (p. ex. pour des scènes/studios ou la navigation maritime)
- meilleure étanchéité et protection anti-poussière

50-2



haacon hebetchnik gmbh

Josef-Haumann-Str. 6
D-97896 Freudenberg/Main

Tel: + 49 (0) 93 75/84-0

Fax: + 49 (0) 93 75/84-86

E-mail: hebetchnik@haacon.de

Internet: <http://www.haacon.com>



Angetriebene Seilwinden Beispiele
Driven rope winches - examples
Treuils à câble entraîné - versions diverses

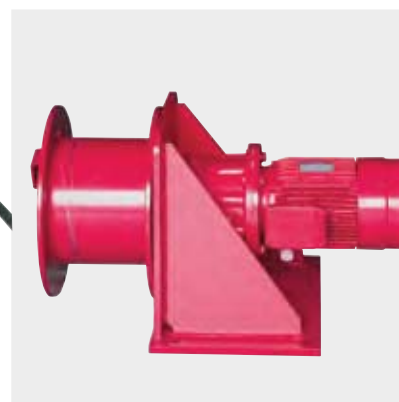
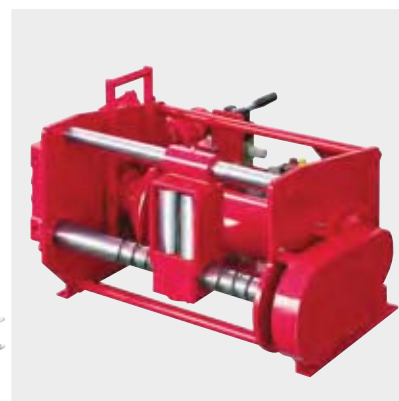
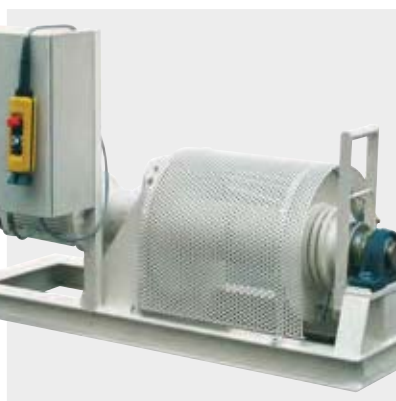
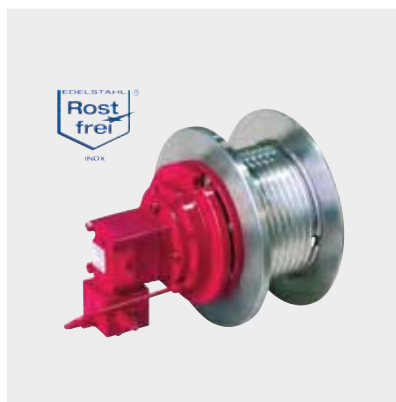

50-1

Winches for Industrial appliance

Professional Series



Sales program 2015 / 2016



haacon hebetchnik gmbh

Josef-Haamann-Str. 6
D-97896 Freudenberg/Main

Tel. + 49 (0) 93 75/84-0

Fax + 49 (0) 93 75/84-86

e-mail: hebetchnik@haacon.de

Internet: <http://www.haacon.com>

General view

Content

General view	2
Application sheet	4
Motors	5
Controls	6
Winch Options	7
Sales program	8
Electric winches ESF	8
Winches FD	10
Electric winches ESG	12
Hydraulic worm gear winches H	14
Pneumatic wormgear winches LV	16
Planetary winches SB	18
Planetary winches SB	20
Planetary compact build winches SC	22
Slew ring winches SR	24
Standard hydraulic planetary crane winches SH	25
Winches C1	26
Personnel lifting winches	28
Personnel lifting winches references	29
Traction winches TR	30
Mooring winches SRM	31
Windlasses W/P/PW	32
Capstans C	34
Accommodation Ladder winches AW/PW	36
Hose reel/Umbilical/Transponder winches HR/UR/TW	38
Application sheet	39
Example for approval drawing	40
References	41
Power	42
Life-time	43



Floating drum winches ESF
Storage up to 26 m
Load range 150-500 kg

Page 8-9



Floating drum winches FD
electric, pneumatic or
hydraulic drive
Load range 950-5.250 kg

Page 10-11



Winches ESG
Large drum capacity
Load range 150-2100 kg

Page 12-13



Hydraulic wormgear
winches H
Load range 500-3150 kg

Page 14-15



Pneumatic wormgear
winches LV
Load range 250-1700 kg

Page 16-17

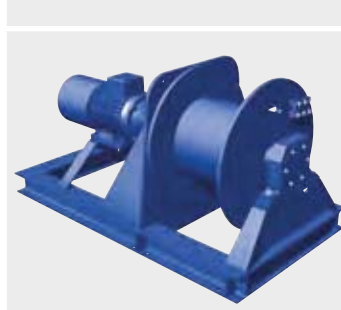

Planetary standard build
winches SB
electric, pneumatic or
hydraulic drive
Load range 1200-37.000 kg

Page 18-21



Planetary compact build winches SC
electric or hydraulic drive
Load range 2000-30.000 kg

Page 22-23

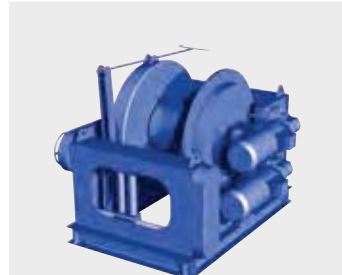

Mooring winches SRM
integrated gears
electric or hydraulic drive
Load range 18.000-36.000 kg

Page 31



Slew ring winches SR
electric or hydraulic drive
Load range 43.000-73.000 kg

Page 24



Windlasses W/P/PW
electric or hydraulic drive
Load range 400-5.500 kg

Page 32



Winches SH
hydraulic drive
Load range 800-10.000 kg

Page 25



Capstans C
electric or pneumatic drive
Load range 500-1.800 kg

Page 34-35



Winches C1
electric drive
for application where people stay under suspended load
Load range 160-1000 kg

Page 26-27

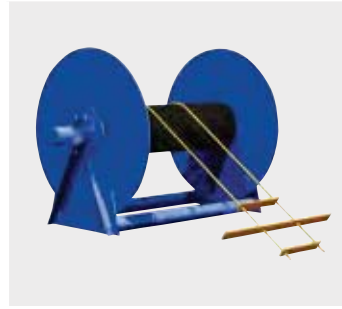

Ladder winches AW/PW
electric or pneumatic drive
Holding force 1500-4.000 kg

Page 36-37



Manriding winches MR FL
pneumatic, hydraulic or electric drive
Load range 200-10.000 kg

Page 28



Spooling winches
Hose and cable reel
electric, pneumatic or hydraulic drive

Page 38



Traction winches TR
electric drive
Load range up to 10.000 kg

Page 30

Do you need winch accessories?

We deliver rope pulleys, idling rollers in different executions and confectioned ropes on request.

(http://www.haacon.de/media/zubehoer/zubehoer_eseilwinden.pdf)

Application sheet

Fax to 0049 (0) 9375- 8486
or via e-mail to hebetechnik@haacon.de

A completable online form is available on:
http://www.haacon.de/media/checklisten/checkliste_angetr_Seilwinden_en.pdf

Company Date.....
Street Phone.....
PO Box Fax
Official in charge..... Email

Pieces.....

REQUIREMENTS:

- Hoisting (vertical) kg
- Pulling (horizontal) kg
- Rope capacity m
- Line speed m/min
- BGV D8¹ BGV C1²
- Temperature °C

MOTOR:

- Electric
- 400 V - AC 230 V - AC 24 V - DC
- Protection IP..... Duty ratio.....
- Indoor use
- Outdoor use

- Hydraulic
- Pressure..... bar
- Flow rate l/min.
- Pneumatic
- Air pressure..... bar
- Air capacity l/s

OPTION:

- Limit switch
- Slack wire switch
- Load limiter
- Disengager/clutch (applicable for pulling winches only)
- Pressure roller
- Grooved drum
- Devided drum
- others.....

CONTROLS:

- Pendant remote control
- Control box with push-buttons
- Radio remote control
- others.....

PAINTING:

- Standard RAL 5010 gentian blue
- Special RAL-N°.::

Documentation/Type plate

- english
- german
- french
- others.....

Application:
.....
.....
.....
.....

¹ German Accident Prevention Regulations (BG) for winches, lifting- and pulling equipment
² German Accident Prevention Regulations (BG) for event areas, studios and scenes

What motor is the best motor to use for a winch, and why?

The choice for the right motor depends mainly on the available power source.

Mobile applications like earth moving machines, piling equipment and mobile cranes normally have a hydraulic power source, they don't carry high power compressors or generators. For these applications a hydraulic motor is selected.

Stationary applications, most of the time can obtain power from the main grid, also on ships the electric power sources become more and more powerful, so an electric motor would be the right choice.

Then we have the so called hazardous environments, where explosions might occur, think of exploitation of natural sources, mining and offshore oil and gas.

Air motors are very common in these fields.

Advantages and disadvantages:

Electric motors	
+	-
economical and efficient	Speed control expensive
clean and simple	Explosion proofing expensive
Energy mostly available	difficult to protect from extreme environment
Hydraulic motors	
+	-
small size	Power pack needed
Speed control easy	Pipes and hoses needed
Pneumatic motors	
+	-
small size	Compressor needed
small size	Pipes and hoses needed
Speed control easy	noisy
suitable for harsh environments	Torque drops with speed

Each winch motor needs a control, after all motors are machines and they don't start moving unless they are told to do so (or to stop for that matter). The manner to control the winch depends on its task. Is it a stand alone lifting tool or a part of a complete automated process, to name just two extremes. There are no „standard“ controls. You can express exactly what is needed. This can vary from the cheapest basic control, to a completely computerized control system. Some control options are shown on page 6.

Electric

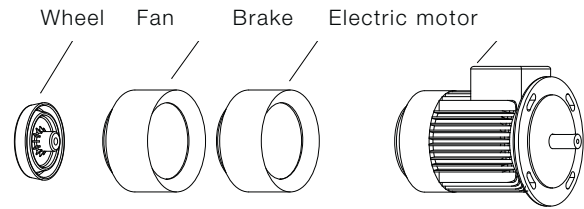

Dust proofing (1)		Water proofing (2)	
Protection class	max. Ø. of object that can penetrate the protection	Protection class	protect against
0	everything	0	nothing
1	under 52,5 mm	1	Tripping from straight top
2	under 12,5 mm	2	Tripping from at angle 0 bis15°
3	under 2,5 mm	3	Spray at max. 60° (rain proof)
4	under 1 mm	4	Water from all directions no pressure
5	semi-dustproof	5	All directions, low pressure
6	dustproof	6	All directions, medium pressure
		7	Immersion at 1m for 30 min.
		8	Immersion no limit

Hydraulic

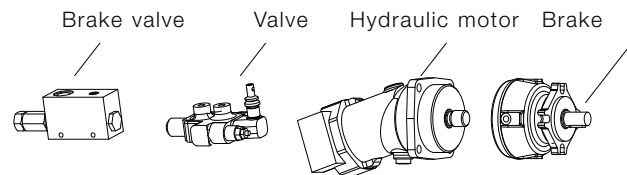

Air vane motor

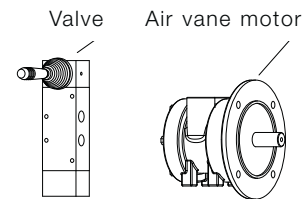

Air piston motor

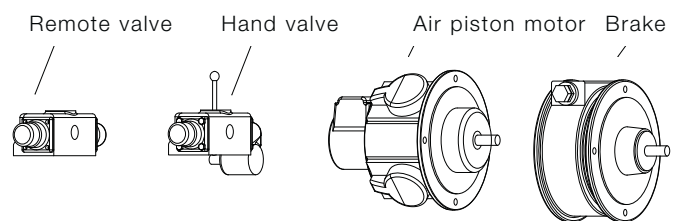

Controls

Electric

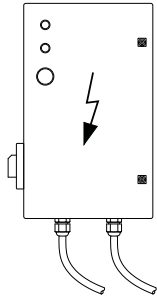

Push Button Up/Down/
Emergency

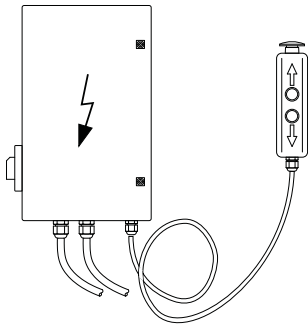

Pendant Control

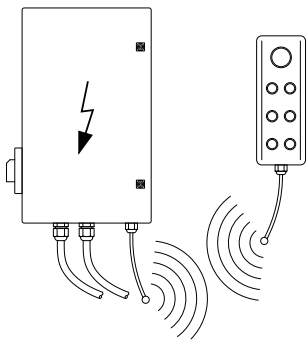

Radio Control

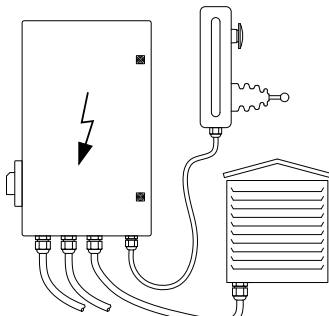

Variable Speed

Hydraulic

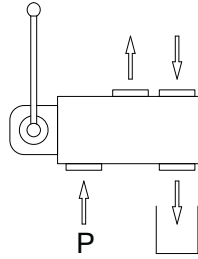

Hydraulic

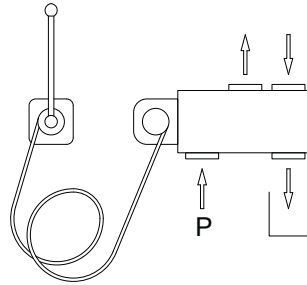

Valve Control

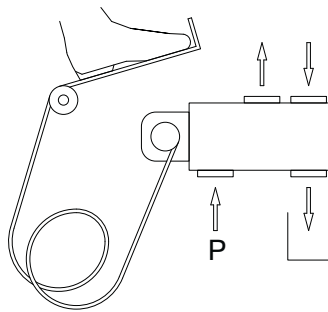

Foot Control

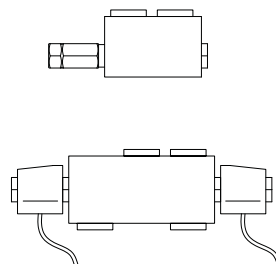

Function Valves

Pneumatic

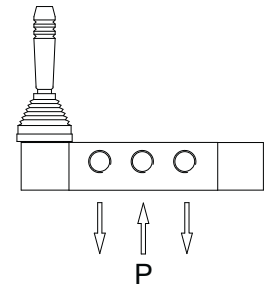

Aluminium Valve

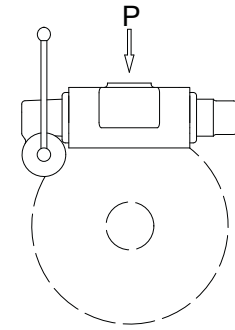

Cast Iron Valve

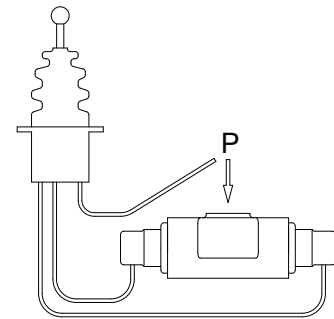

Remote Control

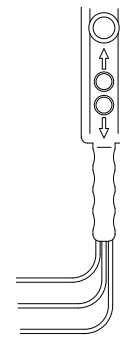

Pendant Control

Limit switch

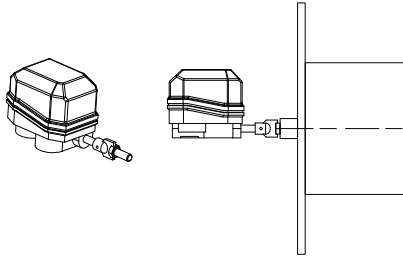

Counts the number of drum revolutions. Limits upper and lower stroke.

Grooved drum

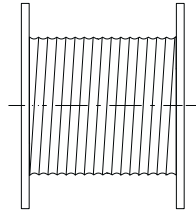

Improved spooling
The rope lasts longer.

Pressure roller

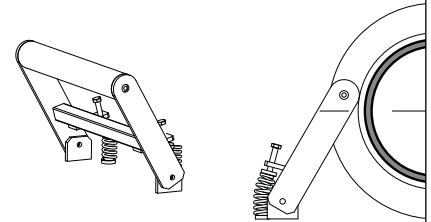

Pushes slack wire to drum, helps to spool the rope better on the drum.

Slack rope device

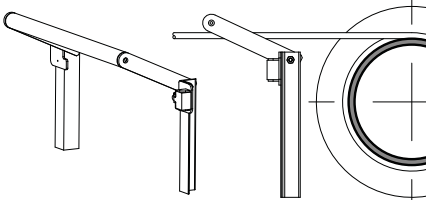

Detects slack wire. Stops the winch.

Clutch

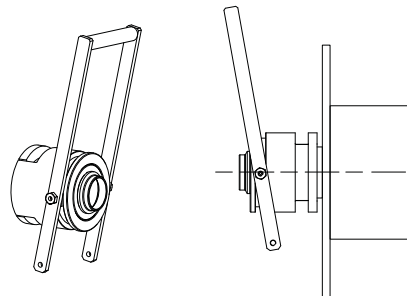

Manual clutch to release the drum.
For use on pulling winches only.

Drum guard

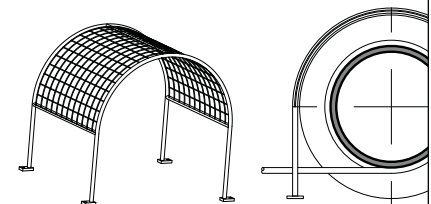

Covers rotating parts, protects the user.

Spooler

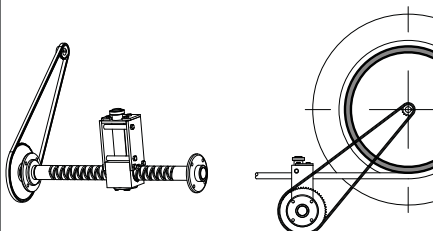

Guides wire on to drum, helps to spool the wire better on the drum.

Band brake

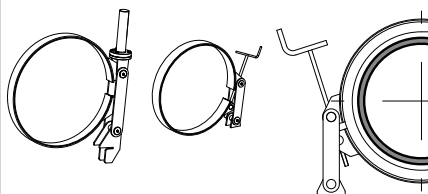

Extra brake fitted on the drum,
manual or automatic.

Emergency crank

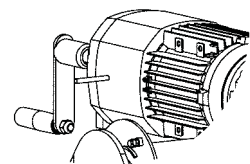

Permits moving the load in case of power blackout.

Sales program

Electric winches ESF

ESF winches are designed as modular rope winches with 230 or 400 V drive flanged on wormgear. The simple design is suitable for many lifting tasks with lower load cycles and small load requirements. The winch can also be easily integrated into the given construction by the mounting holes provided on all sides of the gear-box casing. The wire can take off in any direction. It has a compact design, because the basic configuration only consists of gear, motor, and drum. The robust outward impression of the ESF winch is completed by practical corrosion protection and a combination of high-quality finishing and galvanised parts. The ESF winch is short term available.

Do you need winch accessories? We deliver rope pulleys, idling rollers in different executions, and confectioned ropes on request. (http://www.haacon.de/media/zubehoer/zubehoer_eseilwinden.pdf)

Remark: W.L.L. = Working Load Limit
S.W.L. = Safe Working Load

Standard features

- Worm gear with braked motor IP 55
- Smooth drum
- Single drum support
- 2-component conservation according ISO 12944 category C2-Low, colour RAL 5010 (gentian blue)

Available options

- Grooved drum
- Two drums
- Drum pressure roller
- Special coating systems

Available control options

- Control box IP 65 with push-buttons and emergency stop built acc. to DIN EN 60204 - 32
- Control box IP 65 with low voltage IP 65 remote control built acc. to DIN EN 60204 - 32
- Frequency inverter for variable speed control
- Limit switches
- Slack wire switches
- Load limit switch
- Wireless radio remote control systems

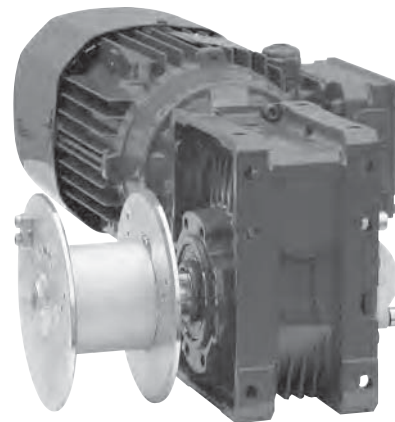

Winch type ESF Electric	WLL 1st Layer kg	WLL 3rd Layer kg	Recommend. Rope Ø mm	Rope speed 1st Layer m/min.	Rope speed 3rd Layer m/min.	Storage 1st Layer m	Storage 3rd Layer m	Max. Storage m	FEM / ISO rating	Power 400 VAC kW	Power 230 VAC kW
ESF 150	150	125 (3)	4	7.2	8.6	3.4	11,5	26 (6)	2m / M5	0.37	-
ESF 200	200	165 (3)	4	7.2	8.6	3.4	11,5	26 (6)	1A _m / M4	-	0.55
ESF 250	250	200 (3)	5	7.2	9.1	2.8	9,6	17.8 (5)	1A _m / M4	0.55	-
ESF 400	400	325 (3)	6	7.5	9.8	3.2	11	20 (5)	1A _m / M4	-	1.1
ESF 500	500	400 (3)	6	7.5	9.8	3.2	11	20 (5)	1B _m / M3	1.1	-

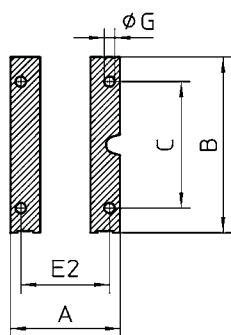
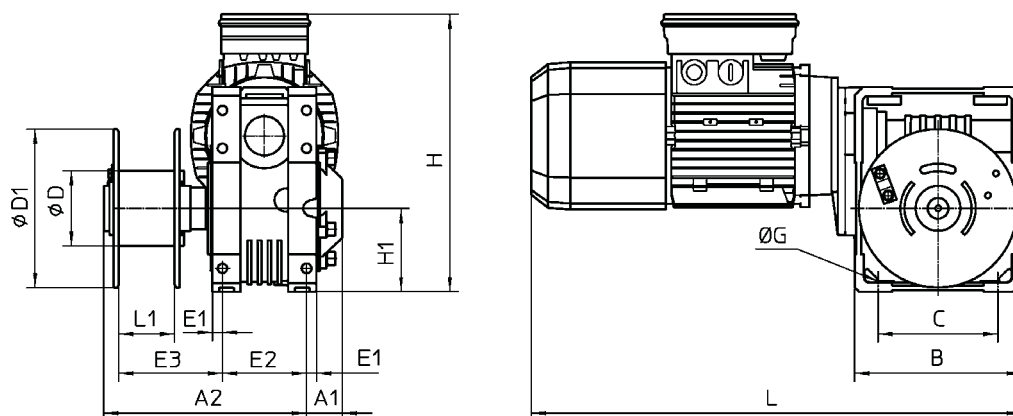

Footprint

Dim.	Mass kg	A	A1	A2	B	C	D	D1	E1	E2	E3	G	H	H1	L	L1
ESF 150	18	94	45	205	145	102	70	140	9	76	111	9	265	72.5	455	61
ESF 200	20	94	45	205	145	102	70	140	9	76	111	9	280	72.5	470	61
ESF 250	22	94	45	205	145	102	70	140	9	76	111	9	278	72.5	485	61
ESF 400	38	125	45	245	200	144	90	190	12	101	125	11,5	345	100	550	67
ESF 500	36,4	125	45	245	200	144	90	190	12	101	125	11,5	335	100	590	67

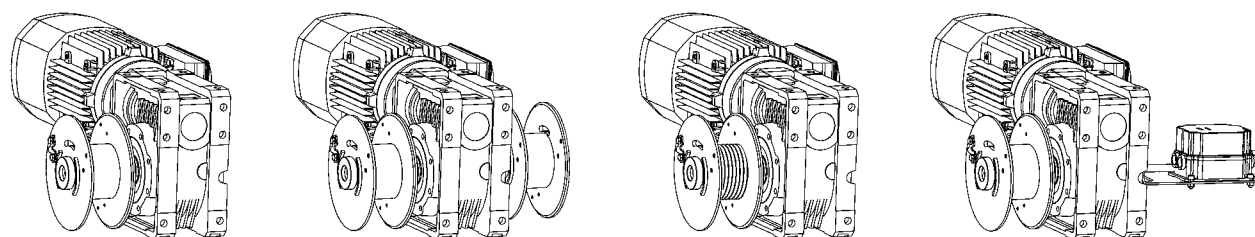

Sales program

Winches FD

Specially designed for applications where space is at a premium, these compact lifting winches are ideally suited for installation on cranes, davits and derricks. The single drum support enables the rope to leave the drum at any angle. The heavy duty planetary drive is partly located within and protected by the drum core. The large drum diameters ensure a healthy drum to cable diameter ratio and a sufficient working length despite the short drums.

Standard features

- Heavy duty planetary gearbox
- FD E; IP 54 400 V AC / 3-phases / 50 Hz braked motor
- FD H; orbit or radial piston type hydraulic motor complete with brake valve
- FD LV; vane type air motor complete with hand control valve and mufflers
- FD GP gear type air motor complete with hand control valve and mufflers
- Smooth drum
- Single drum support
- Double layer 2-component conservation according ISO 12944 category C2-Low, colour RAL 5010 (gentian blue)
- FEM / ISO class: 2_m / M5

Available control options

- Control box IP 55 with push-buttons and emergency stop
- Control box IP 66 with low voltage IP 65 remote control built
- Load limiter (required by CE for applications exceeding 1000 kg WLL)
- Frequency inverter for variable speed control
- Wireless radio remote control systems
- Limit switches
- Slack wire switches
- Radio / Infra red remote control

Available options

- IP 56 TENV cast iron motor for marine applications
- Explosion-proof motors
- Protective steel motor cover
- Drum pressure roller
- Alternative speeds
- Alternative supply voltages
- Drum guards
- Marine / offshore coating systems
- Tubular offshore frame construction with lifting eyes

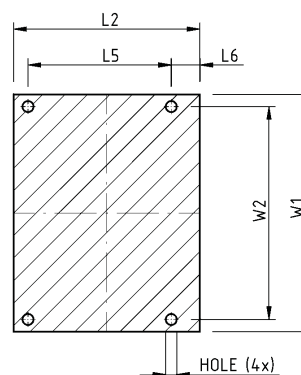
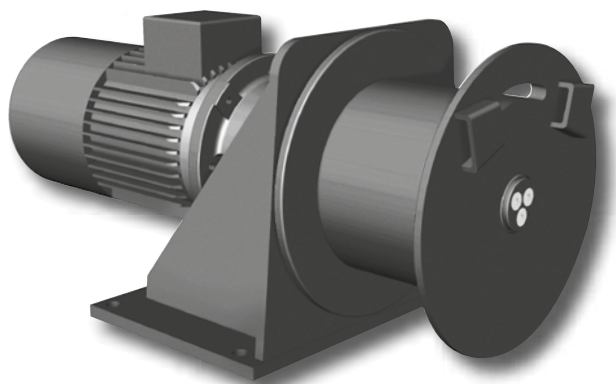
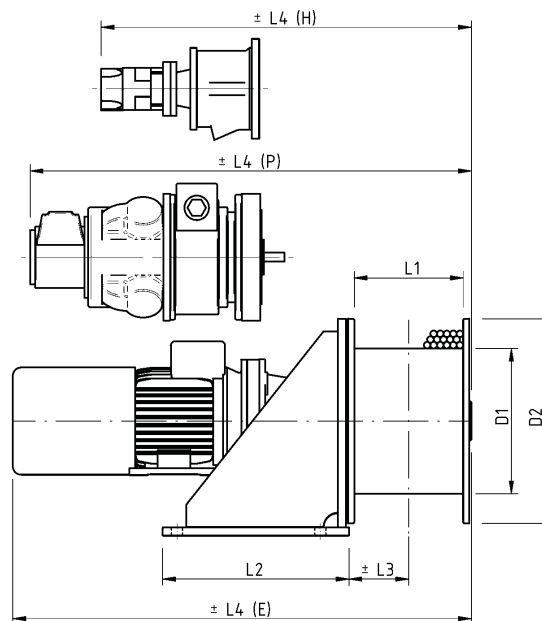
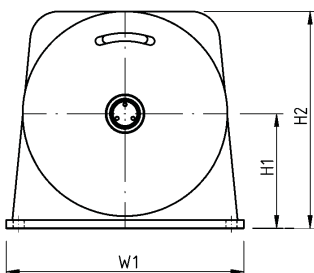

FOOTPRINT
- TOP VIEW -

Winch type Electric	WLL 1 st layer kg	WLL top layer kg	Recomm. rope diam. mm	Speed 1 st layer m/min.	Speed top layer m/min.	Drumcap. 1 st layer m	Drumcap. all layers m	Motor power 400 VAC kW
FD 300 E	950	800 (4)	8	8.5	10	15	70 (4)	1.5
FD 301 E	1850	1470 (4)	11	9	11	10	53 (4)	3
FD 303 E	2300	1970 (3)	12	7	8.5	11	41 (3)	3
FD 304 E	2800	2340 (3)	14	10	12	9	36 (3)	5,5
FD 305 E	3350	2800 (3)	14	9	11	10	40 (3)	5.5
FD 306 E	4100	3500 (3)	16	7	8.5	15	56 (3)	5.5
FD 307 E	5250	4490 (3)	18	12	14	18	67 (3)	11

Winch type Hydraulic	WLL 1 st layer kg	WLL top layer kg	Recomm. rope diam. mm	Speed 1 st layer m/min.	Speed top layer m/min.	Drumcap. 1 st layer m	Drumcap. all layers m	Pressure drop in bar	Flow in l/min.
FD 300 H	950	800 (4)	8	30	35	15	70 (4)	140	35
FD 301 H	1850	1470 (4)	11	20	25	10	53 (4)	130	55
FD 303 H	2300	1970 (3)	12	15	17	11	41 (3)	130	50
FD 304 H	2800	2340 (3)	14	17	20	9	36 (3)	140	60
FD 305 H	3350	2800 (3)	14	13	16	10	40 (3)	135	60
FD 306 H	4100	3500 (3)	16	13	15	15	56 (3)	140	70
FD 307 H	5250	4490 (3)	18	13	15	18	67 (3)	170	70

Winch type Pneumatic	WLL 1 st layer kg	WLL top layer kg	Recomm. rope diam. mm	Average Speed* m/min	Maximum Speed** m/min	Drumcap. 1 st layer m	Drumcap. all layers m	Pressure drop bar	Flow in l/s
FD 300 GP2	950	800 (4)	8	12	18	15	70 (4)	7	65
FD 300 LV	950	800 (4)	8	20	25	15	70 (4)	6,5	90
FD 301 GP2	1500	1200 (4)	11	8	12	10	53 (4)	7	65
FD 301 GP4	1850	1470 (4)	11	10	14	10	53 (4)	7	100
FD 301 LV	1850	1470 (4)	11	10	13	10	53 (4)	6,5	90
FD 303 GP4	2300	1800 (3)	12	9,5	12	11	41 (3)	7	100
FD 303 LV	2300	1970 (3)	12	15	18	11	41 (3)	6,5	150
FD 304 GP4	2600	2200 (3)	14	7,5	10	9	36 (3)	7	100
FD 304 LV	2800	2340 (3)	14	12	14	9	36 (3)	6,5	150
FD 305 LV	3350	2800 (3)	14	10	12	10	40 (3)	6,5	150
FD 306 GP10	4100	3500 (3)	16	15	26	15	56 (3)	7	300
FD 307 GP10	5250	4490 (3)	18	11	20	18	67 (3)	7	300

* AVERAGE SPEED IS BASED ON THE SPEED IN THE MIDDLE LAYER AT 75% OF W.L.L.

** MAXIMUM SPEED IS BASED ON THE SPEED IN THE TOP LAYER AT UNLOADED CONDITIONS

Type	Mass kg	D1	D2	L1	L2	L3	L4(E)	L4(H)	L4(P)	L5	L6	H1	H2	W1	W2	Hole Ø
FD 300	130	244	380	176	310	96	733	520	765	240	44	215	405	440	400	18
FD 301	140	244	380	176	310	96	760	558	785	240	44	215	405	440	400	18
FD 303	180	272	410	191	350	107	818	595	905	275	50	235	440	500	450	22
FD 304	230	272	410	191	350	107	1012	595	905	275	50	235	440	500	450	22
FD 305	255	272	410	210	350	116	1030	625	950	275	50	235	440	500	450	22
FD 306	365	355	500	266	455	146	1098	780	1110	350	70	285	535	580	520	27
FD 307	535	406	625	310	510	172	1316	885	1215	400	75	348	660	750	680	27

Sales program

Electric winches ESG

ESG winches are modular rope winches with 230 or 400 V drive flanged on wormgear or bevel gear. The ESG winch is the "workhorse" in winch construction. The drum is accommodated in a second support bearing. Since winch and drum are always mounted on a base plate, all options for electrical rope winches can be realised. The robust outward impression of the ESG winch is completed by practical corrosion protection and a combination of high-quality finishing and galvanised parts.

The ESG winch is short term available.

Standard features

- Self-braking wormgear / bevel gear transmission IP 55
- Smooth drum
- Two drum supports
- 2-component conservation according ISO 12944 category C2-Low, colour RAL 5010 (gentian blue)

Available options

- Grooved drum
- Devided drum
- Enlarged drum
- Pressure roller
- Clutch
- Special coating

Available control options

- Control box IP 65 with push-buttons and emergency stop built acc.DIN EN 60204 - 32
- Control box IP 65 with low voltage IP 65 remote control built acc. to DIN EN 60204 - 32
- Load limiter (required by CE for applications exceeding 1000 kg WLL)
- Frequency inverter for variable speed control
- Wireless radio remote control systems
- Limit switches
- Slack wire switches

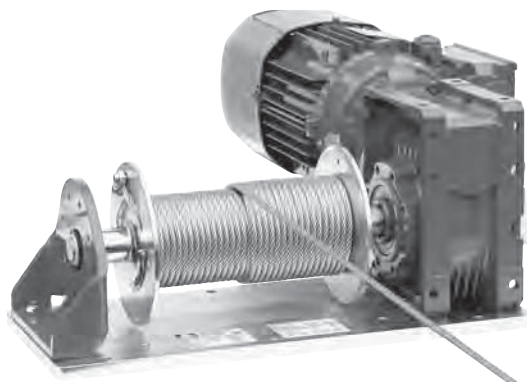

Winch type ESG Electric	WLL 1st Layer kg	WLL 3rd Layer kg	Recommend. Rope Ø mm	Speed 1st Layer m/min.	Speed 3rd Layer m/min.	Storage 1st Layer m	Storage 3rd Layer m	Max. Storage. m	FEM / ISO rating	Power 400 VAC kW	Power 230 VAC kW
ESG 150	150	125	4	7.2	8.6	10	34 (3)	79 (6)	2m / M5	0.37	-
ESG 200	200	165	4	7.2	8.6	10	34 (3)	79 (6)	1Am / M4	-	0,55
ESG 250	250	200	5	7.2	9.1	8	28 (3)	53 (5)	1Am / M4	0.55	-
ESG 400	400	325	6	7.5	9.4	10.5	35 (3)	82 (5)	1Am / M4	-	1.1
ESG 500	500	400	6	7.5	9.4	10.5	35 (3)	82 (6)	1Bm / M3	1.1	-
ESG 650	650	520	7	4.2	5.3	14	48 (3)	138 (5)	1Am / M4	-	1.1
ESG 750	750	590	8	5.1	6.5	12.5	43 (3)	126 (7)	1Bm / M3	1.5	-
ESG 990/1000	990/1000	775	8	4.2	5.5	12	43 (3)	126 (7)	1Bm / M3	1.5	-
ESG 1100	1100	910	9	5	5.9	17	56 (3)	76 (4)	1Am / M4	-	1.1
ESG 1500	1500	1200	11	5	6.1	14	45 (3)	45 (3)	1Am / M4	1.5	-
ESG 2100	2100	1650	11	5	6.1	14	45 (3)	45 (3)	1Cm / M2	2.2	-

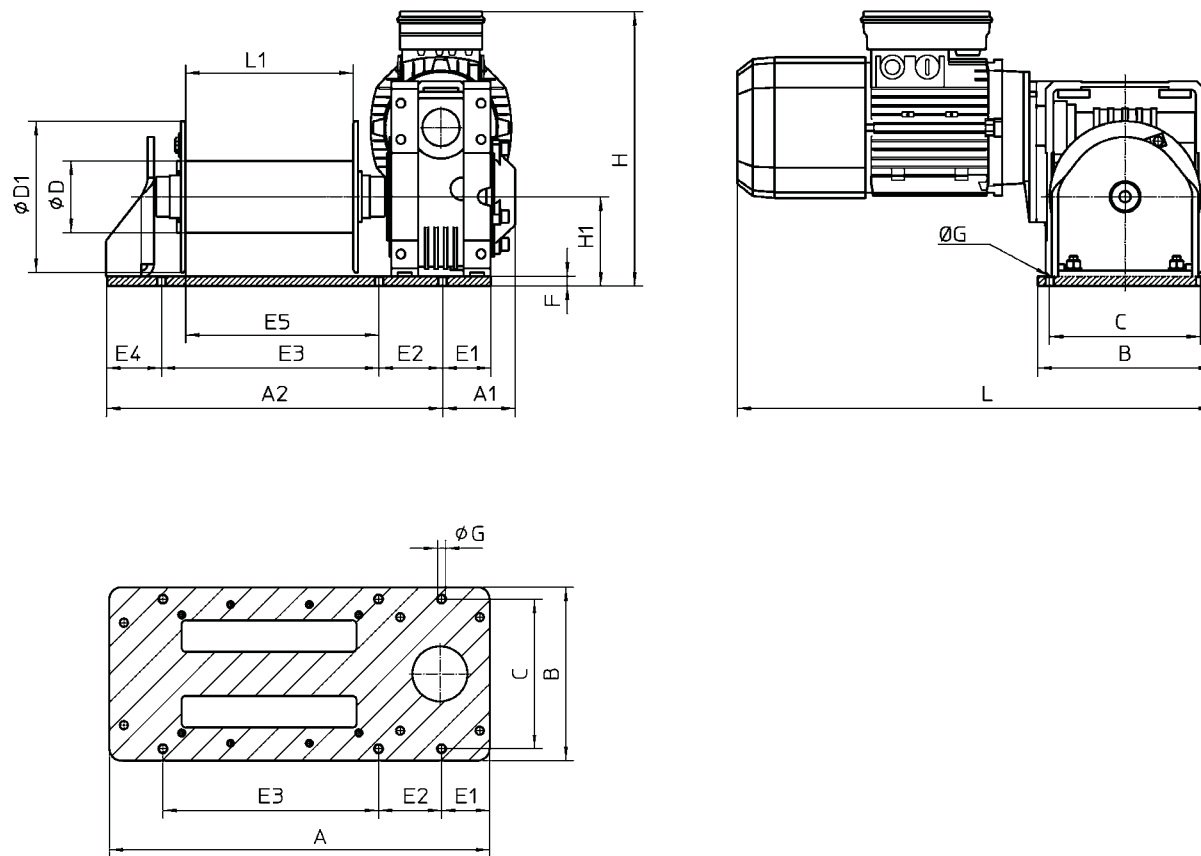

Footprint

Dim.	Mass kg	A	A1	A2	B	C	D	D1	E1	E2	E3	E4	E5	F	G	H	H1	L	L1
ESG 150	29	418	82	370	190	170	70	140	48	60	267	43	218	12	9	280	84,5	480	181
ESG 200	34	418	82	370	190	170	70	140	48	60	267	43	218	12	9	290	84,5	500	181
ESG 250	32,5	418	82	370	190	170	70	140	48	60	267	43	218	12	9	290	84,5	510	181
ESG 400	58	485	424	92	220	190	90	190	61	80	274	70	243,5	12	10,5	356	112	560	211
ESG 500	52,5	485	424	92	220	190	90	190	61	80	274	70	243,5	12	10,5	345	112	600	211
ESG 650	100	581	106	510	260	230	110	248	71	90	350	70	312	15	13	410	140	630	282
ESG 750	90	581	106	510	260	230	110	248	71	90	350	70	312	15	13	400	140	635	282
ESG 990/1000	98	581	106	510	260	230	110	248	71	90	350	70	312	15	13	410	140	680	282
ESG 1100	195	745	23	722,5	380	340	168	275	22,5	250	450	22,5	333	25	17	307	165	862	278
ESG 1500	193	745	23	722,5	380	340	168	275	22,5	250	450	22,5	333	25	17	305	165	903	278
ESG 2100	198	745	23	722,5	380	340	168	275	22,5	250	450	22,5	333	25	17	335	165	950	278

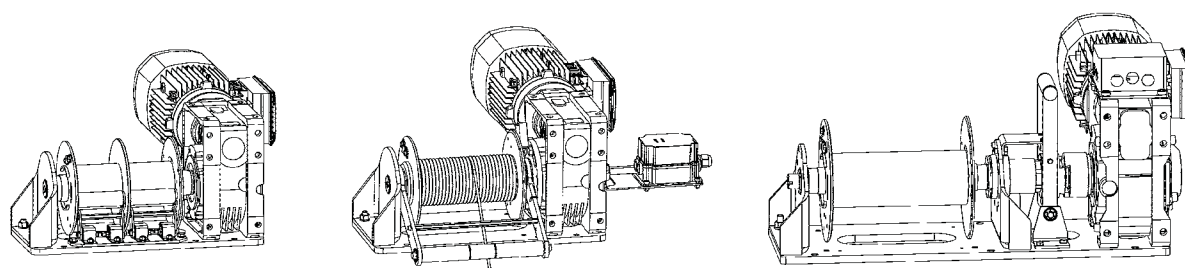

Sales program

Hydraulic worm gear winches H

A range of hydraulic self-braking wormgear winches developed for lifting and pulling applications up to 3,150 kg. Due to the modular concept and the flexibility of our production it is possible to build, with short delivery times, many variations of these winches such that they may be adapted to your specific needs. The types H 500 and H 700 are constructed without a brake and are designed to be totally self-braking. The types H 1200 to H 3150 are designed with a fail-safe brake and brake valve.

Standard features:

- Wormgear transmission
- Orbitmotor
- Smooth drum
- Single drum support (H 500)
- Two drum supports (all other models)
- Double layer 2-component conservation according ISO 12944 category C2-Low, colour RAL 5010 (gentian blue)
- Brake and double acting brake valve (not on H 500 and H 700)
- FEM / ISO class 1B_m / M3

- Available control options:

- Proportional control valves
- Hydraulic power packs

Available options:

- Manual disengaging clutch
- Band brakes, manual or automatic fail safe
- Grooved drum
- Drum pressure roller
- Alternative speeds
- Alternative drum dimensions / split drums / additional rope anchors / etc. Drum guard
- Emergency cranking
- Marine / offshore coating systems

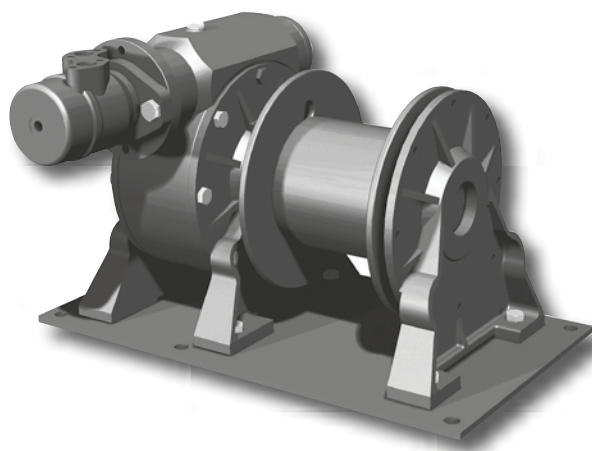

Winch type	WLL 1st layer kg	WLL 3rd layer kg	Recomm. Rope diam. mm	Speed 1st layer m/min.	Drumcap. 1st layer m	Drumcap. 3rd layer m	Pressure drop in bar	Flow in l/min.
H 500 *	500	400	6	6.5	2	10	50	20
H 700 *	700	540	8	6.5	5	20	60	20
H 1200	1200	940	9	9	5	21	95	50
H 2000	2000	1560	12	10	8	28	105	60
H 2500	2500	1965	13	11	9	36	130	60
H 3150	3150	2455	16	8	11	41	140	60

* All winches with brake with the exception of the H 500 and H 700

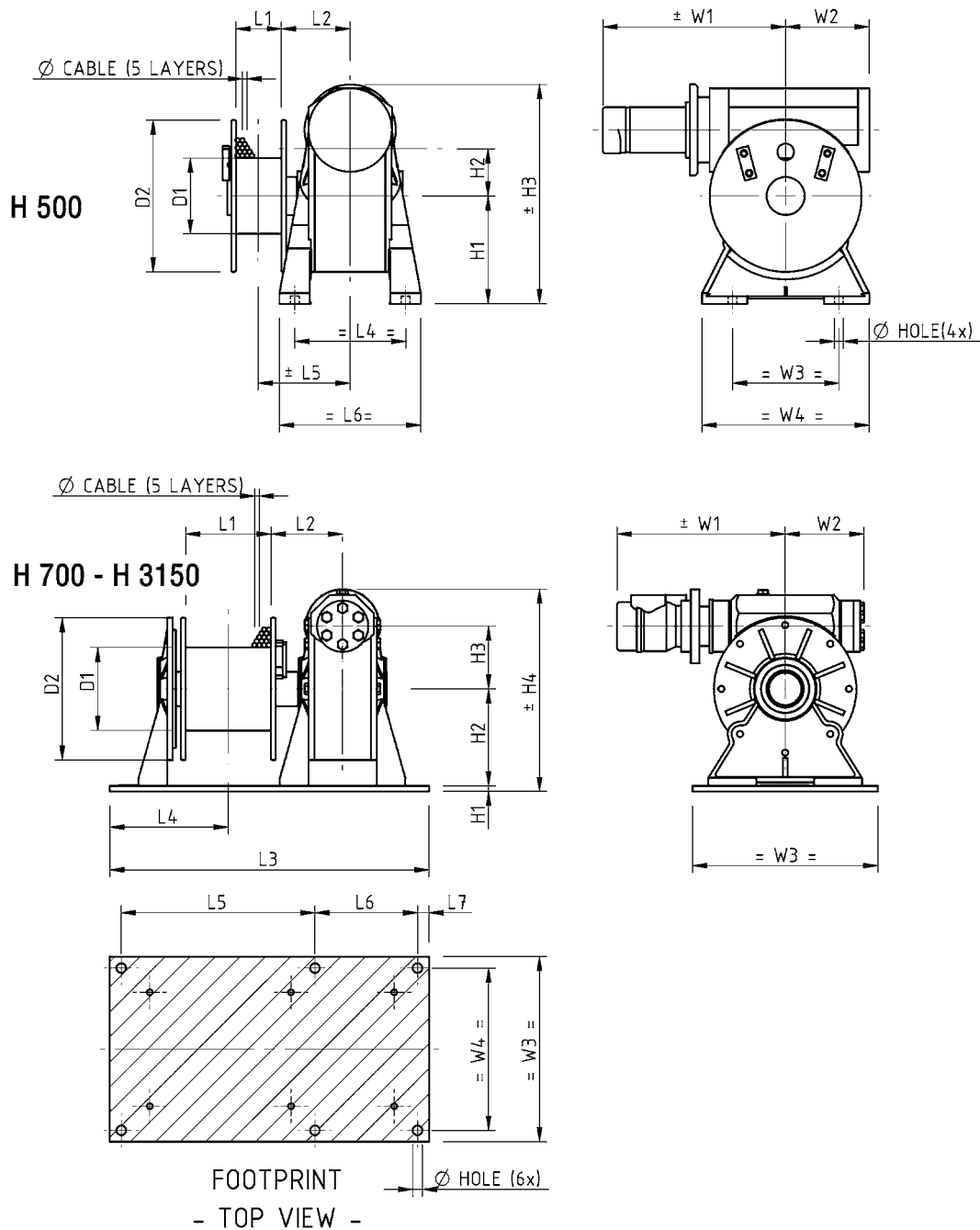

Type	Mass kg	D1	D2	L1	L2	L3	L4	L5	L6	L7	H1	H2	H3	H4	W1	W2	W3	W4	Hole Ø
H 500	35	100	200	60	91	-	146	121	186	-	142	87	289	-	253	110	140	220	11.5
H 700	50	100	200	150	104	500	187	320	150	15	10	142	87	309	253	110	270	240	13
H 1200	82	121	250	150	125.5	560	203	340	180	20	10	170	110	354	400	140	325	285	17
H 2000	134	159	280	200	146.5	640	232	415	185	20	15	195	130	440	456	154	370	320	17
H 2500	170	178	320	250	155	710	280	470	200	20	15	220	150	510	467	180	410	360	17
H 3150	225	210	370	300	180	850	318	565	235	25	15	254	182	572	498	207	440	380	20

Sales program

Pneumatic wormgear winches LV

This range of explosion-proof winches provides the solution for pneumatic winch applications demanding lightweight construction. The use of vane type motors and inherently safe self-braking wormgears ensures trouble-free operation and low maintenance. These winches find their use in general industry, oil and gas exploration, and in many places where compact, explosion-proof hoisting gear is required.

The range includes two fast speed types, the LV 256 and LV 508, which also have optional carrying handles, and slower speed types up to 1700 kg of lifting capacity.

The self-braking properties of the wormgear drive combined with closed ports is sufficient for almost all hoisting purposes. An additional brake may be necessary for accurate positioning of a load. Please consult the factory in this case.

Standard features

- Self-braking wormgear transmission
- Rotary vane motor
- Smooth drum
- Two drum supports
- Double layer 2-component conservation according ISO 12944 category C2-Low, colour RAL 5010 (gentian blue)
- FEM / ISO class 1B_m / M3

Available control options

- Proportional local or remote control valve
- Pneumatic limit switch
- Pneumatic slack wire switch

Available options

- Manual disengaging clutch
- Band brake, manual or automatic fail-safe
- Grooved drum
- Drum pressure roller
- Alternative speeds
- Alternative drum dimensions / split drums / additional rope anchors / etc.
- Drum guard
- Emergency cranking
- Marine / offshore coating systems

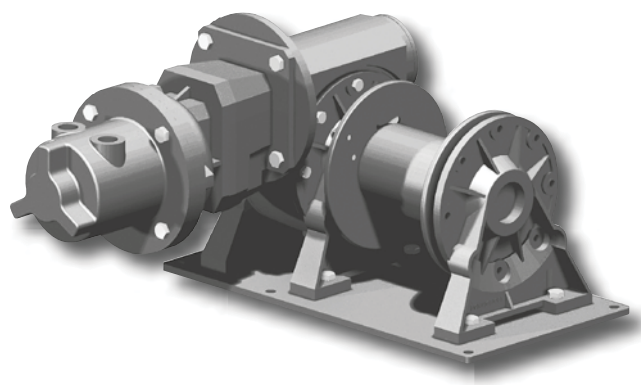

Winch type	WLL 1st layer kg	WLL 3rd layer kg	Recomm. rope diam. mm	Max. speed 1st layer m/min.	Drumcap. 1st layer m	Drumcap. 3rd layer m	Pressure drop in bar	Flow in l/s
LV 256	250	210	5	12	8	30	6,5	60
LV 508	500	400	7	12	6	22	6,5	95
LV 425	425	350	6	5	7	26	6,5	20
LV 750	750	600	8	5.5	6	23	6,5	60
LV 1250	1250	1000	10	6	9	32	6,5	95
LV 1700	1700	1325	12	7	10	35	6,5	140

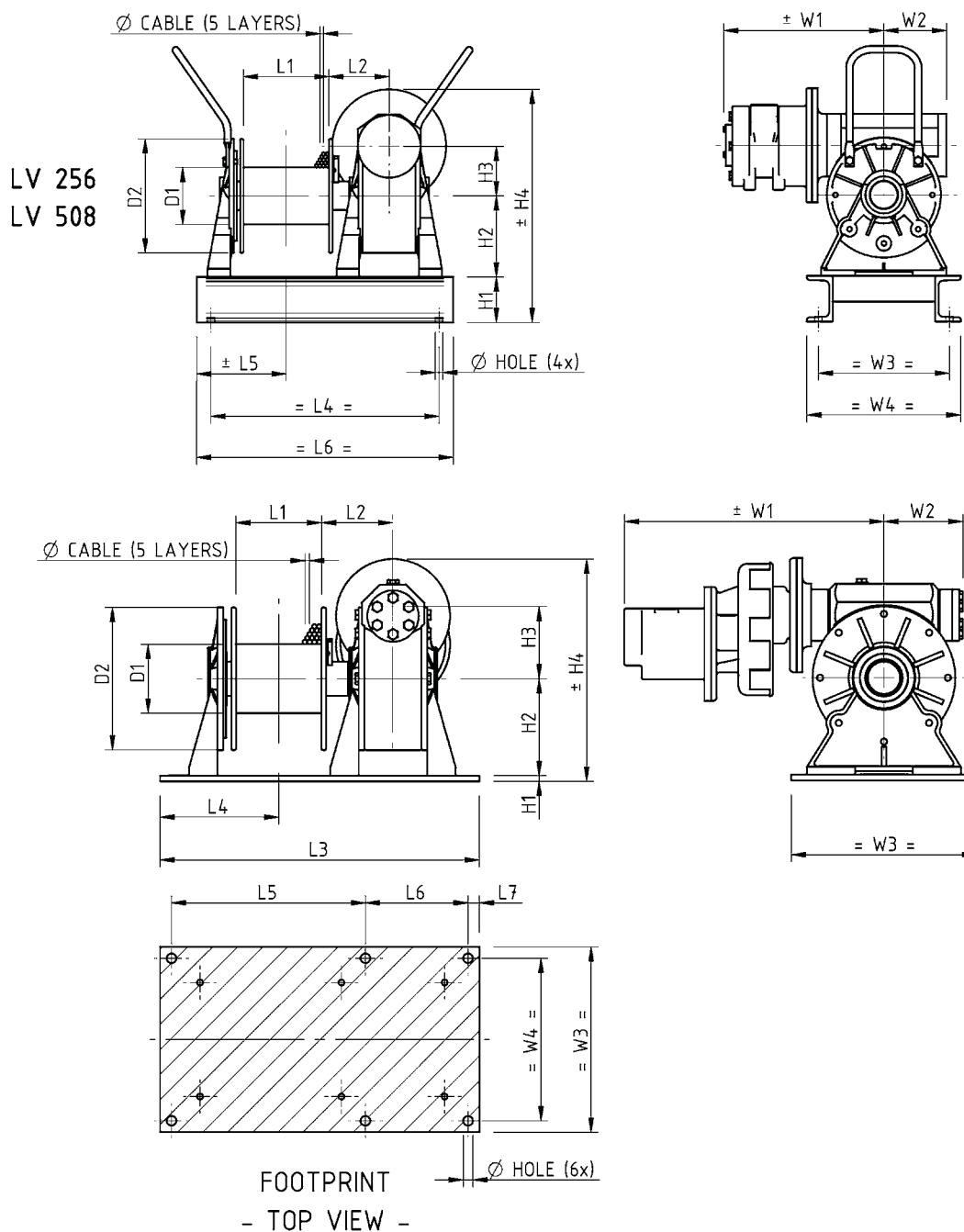

Type	Mass kg	D1	D2	L1	L2	L3	L4	L5	L6	L7	H1	H2	H3	H4	W1	W2	W3	W4	Hole Ø
LV 256	58	100	200	150	105	-	400	157	450	-	80	142	87	409	278	110	270	230	13
LV 425	59	100	200	150	105	500	187	320	150	15	10	142	87	389	374	110	270	240	13
LV 508	65	100	200	150	105	-	400	157	450	-	80	142	87	409	281	110	270	230	13
LV 750	93	121	250	150	125.5	560	203	340	180	20	10	170	110	390	455	140	325	285	17
LV 1250	149	146	280	200	146.5	640	232	415	185	20	15	195	130	440	490	154	370	320	17
LV 1700	192	159	320	250	155	710	260	470	200	20	15	220	150	510	609	180	410	360	17

Sales program

Planetary winches SB

The SB type winch provides the basis of the solution to many pulling and lifting winch applications. The winch is constructed in the conventional manner with motor, gearbox and drum in line. Capacities can go up to 70 tons of lifting capacity with this range.

These winches are very suitable to suit your specific winch application. Many options can be offered on these highly versatile winches.

Standard winch features

- Heavy duty planetary gearbox
- SB E; IP 54 400 V AC / 3-phases / 50 Hz braked motor
- SB H; orbit or radial piston type hydraulic motor complete with brake valve
- SB LPR; radial piston type air motor complete with hand control valve and mufflers
- SB LG; gear type air motor complete with hand or remote control valve and mufflers
- Load limiter (required by CE for applications exceeding 1000 kg WLL)
- Smooth drum
- Two drum supports
- Double layer 2-component conservation according ISO 12944 category C2-Low, colour RAL 5010 (gentian blue)
- FEM / ISO class: 1A_m / M4

Available winch options

- IP 56 TENV cast iron motor for marine applications
- Explosion-proof motors
- Protective steel motor cover
- Drum pressure roller
- Band brakes (manual or fail-safe automatic)
- Manual disengaging clutch
- Alternative speeds

- Alternative supply voltages
- Drum guards
- Spooling gears
- Grooved drums
- Manual emergency crank
- Slip ring mounting
- Alternative drum dimensions / split drums / additional rope anchors / etc.
- Warping head
- Marine / offshore coating systems

Available control options

- Control box IP 55 with push-buttons and emergency stop
- Control box IP 66 with low-voltage IP 65 remote control built
- Frequency inverter for variable speed control
- Wireless radio remote control systems
- Limit switches (electric, pneumatic)
- Slack wire switches (electric, pneumatic)
- Proportional local or remote control valve (pneumatic or hydraulic)

Winch type Electric	WLL 1 st layer kg	WLL 5 th layer kg	Recomm. rope diam. mm	Speed 1 st layer m/min.	Speed 5 th layer m/min.	Drumcap. 1 st layer m	Drumcap. 5 th layer m	Motor power kW
SB 300 E	1200	845	10	9,5	14	26	168	2.2
SB 301 E	2100	1435	12	7	10	24	157	3
SB 303 E	2500	1740	14	11	16	26	165	5.5
SB 304 E	3100	2160	14	9	13	26	165	5.5
SB 305 E	4000	2770	16	7	10.5	25	161	5.5
SB 306 E	5500	3970	18	7	10	28	181	7.5
SB 307 E	7000	4960	22	12	17	26	171	15
SB 309 E	9000	6285	26	14	19.5	24	163	22
SB 310 E	12000	8460	28	8	12	24	168	18.5
SB 311 E	16000	10655	34	7	11	19	144	22
SB 313 E	20000	13610	38	6	8.5	19	151	22
SB 314 E	24000	16170	40	6.5	9.5	19	154	30
SB 315 E	30500	20800	44	6	9	19	151	37
SB 316 E	37000	24570	48	6	9	17	141	45

Sales program

Winch type Hydraulic	WLL 1 st layer kg	WLL 5 th layer kg	Recomm. rope diam. mm	Speed 1 st layer m/min	Speed 5 th layer m/min	Drumcap. 1 st layer m	Drumcap. 5 th layer m	Pressure drop in bar	Flow in l/min.
SB 303 H	2500	1740	14	18	26	26	165	140	60
SB 304 H	3100	2160	14	15	21	26	165	140	60
SB 305 H	4000	2770	16	18	26	25	161	190	70
SB 306 H	5500	3970	18	25	35	28	181	225	95
SB 307 H	7000	4960	22	20	28	26	171	230	100
SB 309 H	9000	6285	26	13	18	24	163	190	100
SB 310 H	12000	8460	28	11	16	24	168	230	95
SB 311 H	16000	10655	34	10	15	19	144	230	110
SB 313 H	20000	13610	38	8	12	19	151	210	120
SB 314 H	24000	16170	40	8	11	19	154	240	120
SB 315 H	30500	20800	44	8	12	19	151	235	165
SB 316 H	37000	24570	48	6	9	17	141	225	160

Winch type Pneumatic Piston motor	WLL 1 st layer kg	WLL 5 th layer kg	Recomm. Rope diam. mm	Average Speed* m/min.	Maximum Speed** m/min.	Drumcap. 1 st layer m	Drumcap. 5 th layer m	Pressure drop in bar	Flow in l/s
SB 300 LPR2	1200	845	10	13	18	26	168	7	90
SB 301 LPR2	2100	1435	12	8	12	24	157	7	90
SB 303 LPR2	2500	1740	14	7	10	26	165	7	90
SB 303 LPR3	2500	1740	14	15	26	26	165	7	140
SB 304 LPR3	3100	2160	14	13	19	26	165	7	140
SB 305 LPR3	4000	2770	16	11	17	25	161	7	140
SB 305 LPR4	4000	2770	16	18	24	25	161	7	240
SB 306 LPR4	5500	3970	18	12	15	28	181	7	240
SB 307 LPR4	7000	4960	22	10	13	26	171	7	240
SB 309 LPR4	9000	6285	26	8	12	24	163	7	240

Winch type Pneumatic Gear motor	WLL 1 st layer kg	WLL 5 th layer kg	Recomm. Rope diam. mm	Average Speed* m/min.	Maximum Speed** m/min.	Drumcap. 1 st layer m	Drumcap. 5 th layer m	Pressure drop in bar	Flow in l/s
SB 300 GP4	1200	845	10	18	23	26	168	7	100
SB 301 GP4	2100	1435	12	10	15	24	157	7	100
SB 303 GP4	2500	1740	14	8,5	11	26	165	7	100
SB 304 GP10	3100	2160	14	22	42	26	165	7	300
SB 305 GP10	4000	2770	16	17	33	25	161	7	300
SB 306 GP10	5500	3970	18	12	23	28	181	7	300
SB 307 GP10	7000	4960	22	10	18	26	171	7	300
SB 307 GP16	7000	4960	22	15	35	26	171	7	350
SB 309 GP10	9000	6285	26	7	13	24	163	7	300
SB 309 GP16	9000	6285	26	11	27	24	163	7	350
SB 310 GP16	12000	8460	28	8	20	24	168	7	350
SB 311 GP16	16000	10655	34	6	15	19	144	7	350
SB 313 GP16	20000	13610	38	5	12	19	151	7	350

* Average speed is based on the speed in the middle layer at 75% of W.L.L.

** Maximum speed is based on the speed in the top layer at unloaded conditions

Sales program

Planetary winches SB

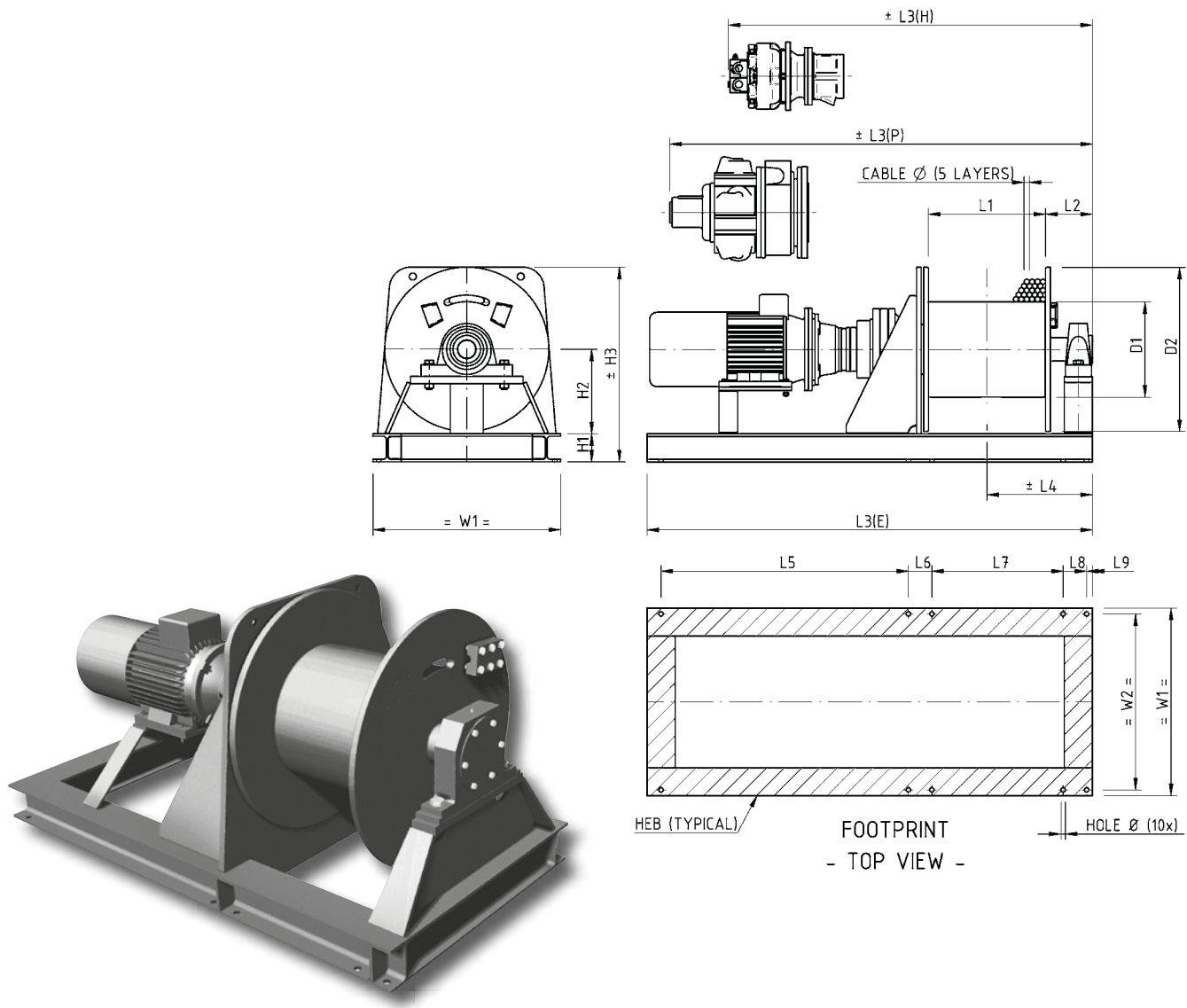

Winch type	Mass kg	D1	D2	L1	L2	L3(E)	L3(H)	L3(P)	L4	L6	L7	L8	L9	H1	H2	H3	W1	W2	HEB	Hole Ø
300	260	178	410	500	135	1400	-	1450	385	80	530	80	20	100	215	520	500	460	100	14
301	270	195	410	500	140	1400	-	1450	390	80	530	80	20	100	215	520	500	460	100	14
303	390	244	500	500	145	1650	1350	1650	395	80	540	80	20	100	260	610	600	560	100	14
304	405	244	500	500	145	1650	1350	1800	395	80	540	80	20	100	260	610	600	560	100	14
305	410	272	500	500	155	1700	1350	1800	405	80	550	80	20	100	260	610	600	560	100	14
306	525	355	600	500	155	1700	1450	1850	405	80	550	80	20	100	310	710	700	660	100	18
307	825	406	700	500	200	1950	1550	1900	450	100	560	100	25	120	360	830	800	750	120	20
309	1215	455	850	500	230	2100	1550	1900	480	110	580	110	30	140	435	1000	1000	940	140	22
310	1470	508	900	500	230	2100	1600	1950	480	120	550	120	40	160	460	1070	1100	1040	160	26
311	1690	508	1000	500	245	2150	1600	1950	495	120	570	120	40	160	510	1170	1150	1090	160	30
313	2270	610	1150	500	265	2250	1700	1950	515	120	600	120	40	180	585	1340	1350	1280	180	33
314	3200	660	1250	500	265	2500	2000	-	515	140	600	140	40	200	635	1460	1450	1370	200	39
315	3550	711	1350	500	300	2650	2050	-	550	140	610	140	40	200	685	1560	1550	1470	200	39
316	3865	711	1400	500	305	2700	2100	-	565	140	615	140	40	200	710	1610	1600	1520	200	39

SB 303 EDGP

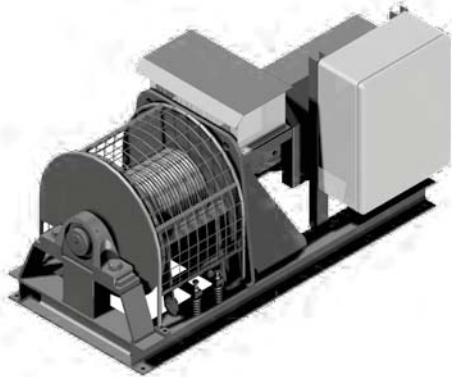

SB 303 EDGP INCLUDING DRUM GUARD, GROOVED DRUM , PRESSURE ROLLER, RAINCOVER OVER MOTOR, AND CONTROL PANEL WITH FREQUENCY INVERTER

SB 311 R EDPS

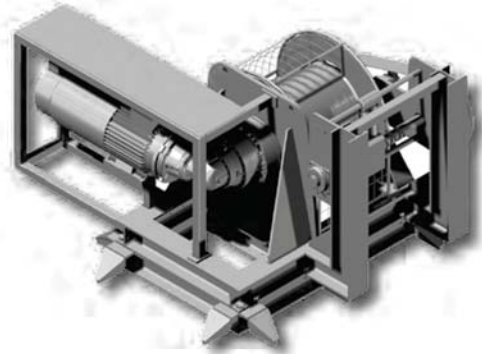

SB 311 R EDPS INCLUDING RIGHT ANGLE GEARBOX, DRUM GUARD, PROTECTIVE FRAME AROUND MOTOR, SPOOLING GEAR AND COUNTER FOUNDATION FOR DECK WELDING

SB 310 H



SB 310 H INCLUDING PROPORTIONAL CONTROL VALVE AND FILTER UNIT

SB 310 HDPS

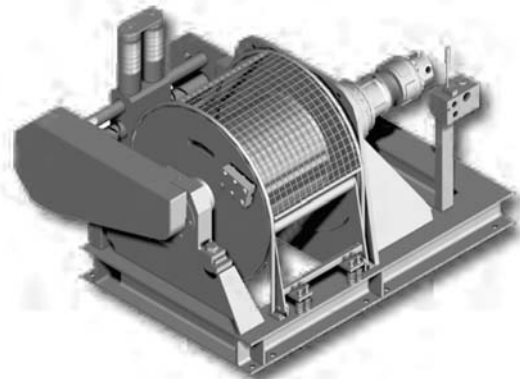

SB 310 HDPS INCLUDING DRUM GUARD, PRESSURE ROLLER, SPOOLING GEAR AND PROPORTIONAL CONTROL VALVE

SB 306 GP16P

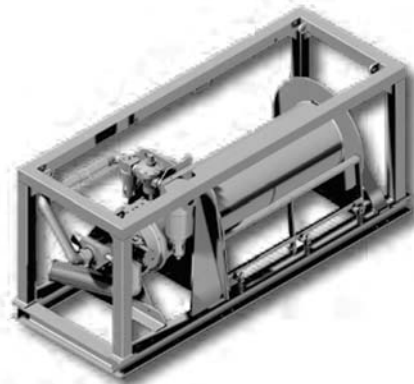

SB 306 GP16P INCLUDING PRESSURE ROLLER, AIR SERVICE UNIT AND OFFSHORE FRAME

Sales program

Planetary compact build winches SC

A range of compact lifting and pulling winches utilising electric or hydraulic motors.

The heavy duty planetary gearbox is located within the drum core, which both saves space and protects the gearbox from any external mechanical threats.

Capacities can go up to 30 tons of lifting capacity with this range. Depending on your power source and application, we can select and offer the correct model for you.

Standard features

- Heavy duty planetary gearbox
- SC E IP 54 400 V AC / 3-phases / 50 Hz braked motor
- SC H; orbit or radial piston type hydraulic motor complete with brake valve
- Load limiter (required by CE for applications exceeding 1000 kg WLL.)
- Smooth drum
- Two drum supports
- Double layer 2-component conservation according ISO 12944 category C2-Low, colour RAL 5010 (gentian blue)
- FEM / ISO class: 2m / M5

Available options

- IP 56 TENV cast iron motor for marine applications
- Explosion-proof motors
- Protective steel motor cover
- Drum pressure roller
- Band brakes (manual or fail-safe automatic)
- Manually disengaging clutch

- Alternative speeds
- Alternative supply voltages
- Drum guards
- Spooling gears
- Grooved drums
- Marine / offshore coating systems

Available control options

- Control box IP 55 with push-buttons and emergency stop
- Control box IP 66 with low-voltage IP 65 remote control
- Frequency inverter for variable speed control
- Wireless radio remote control systems
- Limit switches (electric)
- Flange encoder
- Slack wire switches (electric)
- Proportional local or remote control valve (hydraulic)

Winch type	WLL 1 st layer kg	WLL. top layer kg	Recomm. rope diam. mm	Speed 1 st layer m/min.	Speed top layer m/min.	Drumcap. top layer m	Motor power in kW
SC 15 E	1955	1500 (5)	12	8	10	178 (5)	3
SC 20 E	2655	2000 (5)	13	11	14	167 (5)	5,5
SC 25 E	3500	2500 (5)	16	8	11	144 (5)	5,5
SC 35 E	4850	3500 (5)	18	8	11	181 (5)	7,5
SC 50 E	6880	5000 (5)	20	8	11	203 (5)	11
SC 67 E	9700	6700 (5)	24	12	17	195 (5)	22
SC 85 E	12160	8500 (5)	26	9	13	228 (5)	22
SC 110 E	15910	11000 (5)	30	7	10	228 (5)	22
SC 140 E	18555	14000 (4)	32	6	8	204 (4)	22
SC 175 E	23215	17500 (4)	38	6,5	8,5	223 (4)	30
SC 220 E	29550	22000 (4)	40	6	8	214 (4)	37

Winch type	WLL 1 st layer kg	WLL. top layer kg	Recomm. rope diam. mm	Speed 1 st layer m/min.	Speed top layer m/min.	Drumcap. top layer m	Flow in l/min.	Pressure drop in bar
SC 15 H	1955	1500 (5)	12	19	25	178 (5)	60	125
SC 20 H	2655	2000 (5)	13	11	14	167 (5)	60	115
SC 25 H	3500	2500 (5)	16	12	16	144 (5)	60	135
SC 35 H	4850	3500 (5)	18	11	15	181 (5)	60	160
SC 50 H	6880	5000 (5)	20	12	16	203 (5)	70	200
SC 67 H	9700	6700 (5)	24	12	17	195 (5)	90	220
SC 85 H	12160	8500 (5)	26	12	17	228 (5)	100	235
SC 110 H	15910	11000 (5)	30	10	14	228 (5)	120	220
SC 140 H	18555	14000 (4)	32	9	12	204 (4)	115	250
SC 175 H	23215	17500 (4)	38	10	13	223 (4)	155	240
SC 220 H	29550	22000 (4)	40	9	12	214 (4)	175	245

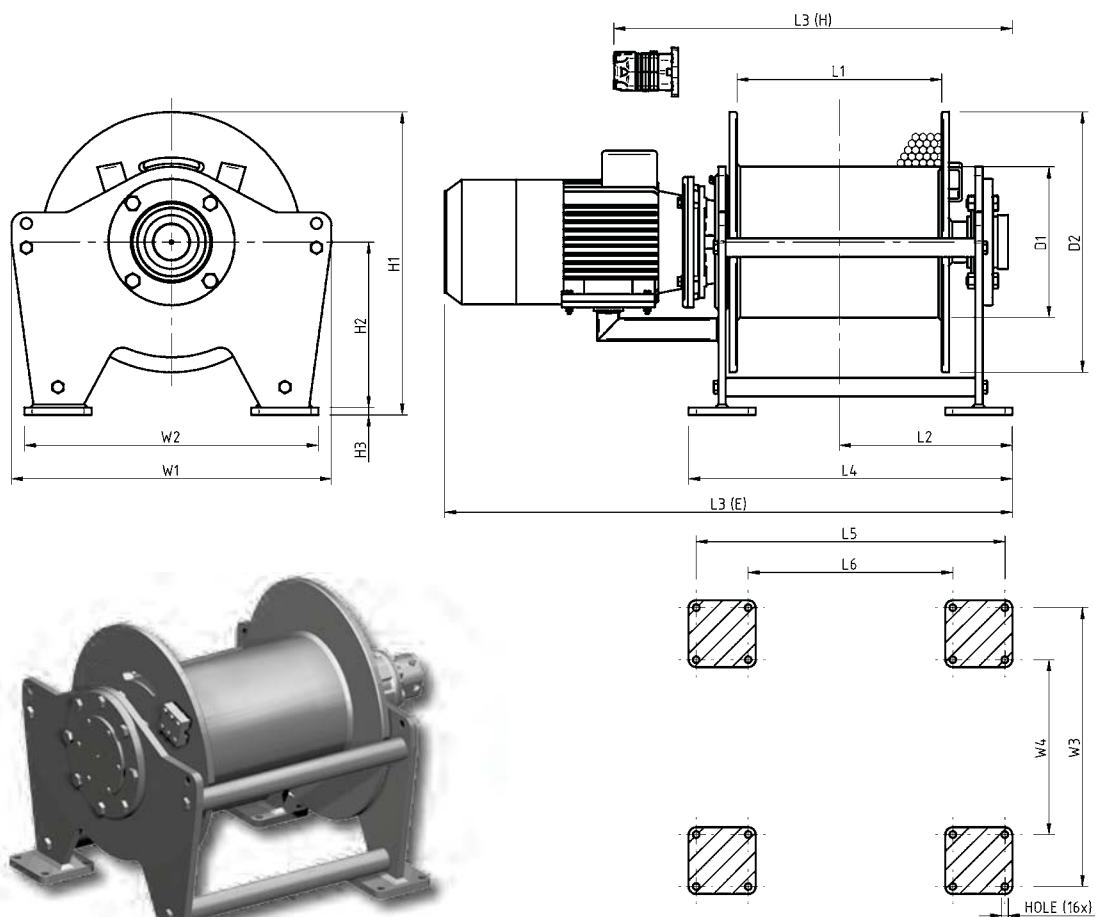

FOOTPRINT -TOP VIEW- A-A

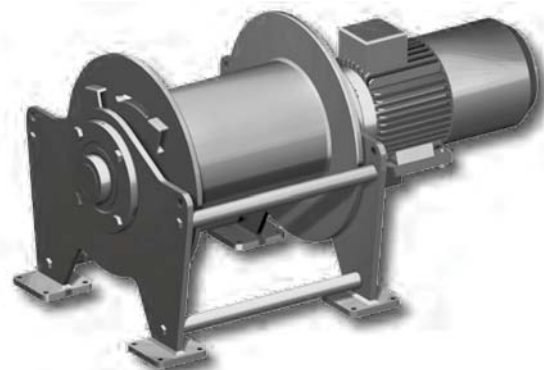
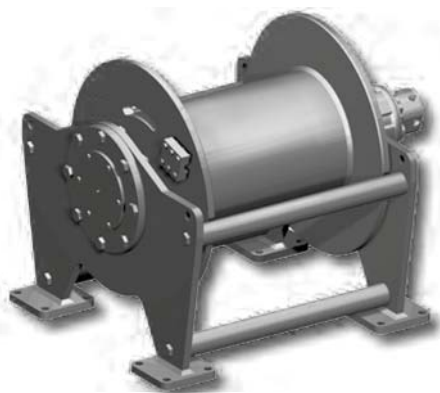

Type	Mass kg	D1	D2	L1	L2	L3 E	L3 H	L4	L5	L6	H1	H2	H3	W1	W2	W3	W4	Hole Ø
SC 15	315	305	500	400	322	1012	812	625	595	375	610	345	15	660	550	520	300	14
SC 20	425	305	500	400	360	1246	872	680	640	400	615	345	20	660	570	530	290	14
SC 25	470	305	550	410	375	1266	887	700	660	420	665	370	20	710	620	580	340	14
SC 35	660	355	700	500	430	1382	973	810	770	490	815	445	20	860	790	750	470	18
SC 50	810	405	700	550	465	1526	1071	870	830	550	815	445	20	860	790	750	470	18
SC 67	1120	405	750	610	528	1718	1192	980	930	630	870	470	25	950	860	810	510	26
SC 85	1350	455	850	690	582	1816	1332	1075	1025	725	970	520	25	1050	960	910	610	26
SC 110	1675	508	950	720	623	1950	1412	1140	1090	750	1070	570	25	1150	1080	1030	690	26
SC 140	2245	558	1050	820	685	2062	1495	1280	1220	820	1170	615	30	1330	1220	1160	760	33
SC 175	2920	660	1150	900	735	2353	1814	1380	1300	900	1270	665	30	1430	1340	1260	860	39
SC 220	3450	660	1250	900	748	2487	1848	1400	1320	920	1375	715	35	1530	1440	1360	960	39

Sales program

Slew ring winches SR

The standard build SR type winch is the basis of the solution to many pulling and lifting winch applications. The winch is constructed with a slew ring in a combination with 3 or more planetary drives and motors. Capacities can go up to 75 tons of lifting capacity with this range.

These winches are very suitable to suit your specific winch application. Several options can be offered on these highly versatile winches. Prices and drawings will be supplied upon request.

Standard winch features

- Heavy duty slew ring
- Heavy duty planetary gearboxes fitted with pinions
- SR E IP 54 400 V AC / 3-phases / 50 Hz braked motors
- SR H orbit or radial piston type hydraulic motor complete with brake valve
- Load limiter (required by CE for applications exceeding 1000 kg WLL)
- Smooth drum
- Double layer 2-component conservation according ISO 12944 category C2-Low, colour RAL 5010 (gentian blue)
- FEM / ISO class: 1A_m / M4

Available control options

- Control box IP 55 with pushbuttons and emergency stop
- Control box IP 66 with low voltage IP 65 remote control
- Frequency inverter for speed control
- Wireless radio remote control systems
- Limit switches
- Slack wire switches
- Proportional local or remote control valve

Available winch options

- IP 56 TENV cast iron motors
- Explosion-proof motors
- Protective steel motor cover
- Band brakes (manual or fail-safe automatic)
- Alternative speeds
- Alternative supply voltages
- Drum guards
- Spooling gears
- Grooved drums
- Slip ring or swivel mounting
- Alternative drum dimensions / split drums / additional rope anchors / etc. Warping head
- Marine / offshore coating systems
- Tubular offshore frame with lifting eyes

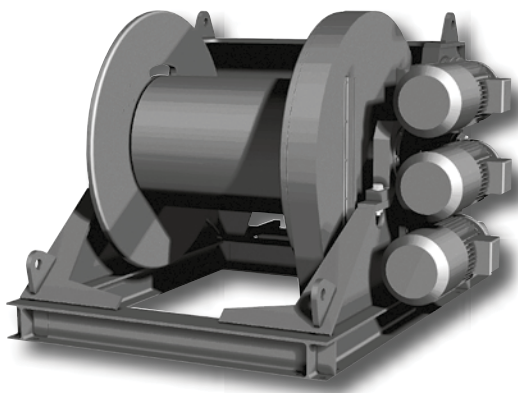

Winch type	WLL 1 st layer kg	WLL 5 th layer kg	Recomm. rope diam. mm	Speed 1 st layer m/min.	Speed 5 th layer m/min.	Drumcap. 1 st layer m	Drumcap. 5 th layer m	Motor power kW
SR 30 E3	43000	30000	44	7	10	42	290	66
SR 40 E3	57000	40000	52	6	8	40	290	66
SR 50 E4	73000	50000	56	6	8	37	275	74
SR 30 H3	41000	30000	44	7	10	42	290	66
SR 40 H3	57000	40000	52	6	8	40	290	66
SR 50 H4	73000	50000	56	6	8	37	275	74

Standard hydraulic planetary crane winches SH

A range of standard hydraulic planetary winches, developed for heavy duty lifting and pulling applications of up to 10,000 kg where compactness is required. Due to the standard design, they can be supplied within short delivery times. All winches are fitted with a brake as standard that makes them suitable for lifting applications.

Standard features

- Planetary transmission
- Orbit motor
- Steel drum (not grooved) with cable fixing point at flange
- Two drum supports
- Single layer of primer only, colour black
- Brake and single acting brake valve

Available control options

- Proportional control valves
- Hydraulic power packs
- Electric lower limit switch
- Load limiter

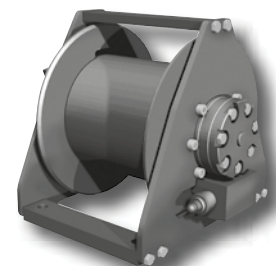

Available options

- Grooved drum
- Drum pressure roller
- Drum guards
- Marine / offshore coating systems

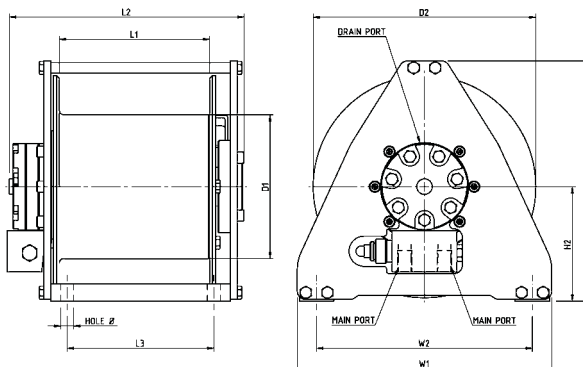

Winch type Hydraulic	WLL 1 st layer kg	WLL top layer kg	Recomm. rope diam. mm	Speed 1 st layer m/min.	Drumcap. 1 st layer m	Drumcap. all layers m	Pressure drop in bar	Flow in l/min.	Main ports BSP	Drain ports BSP
SH 08	800	610	7	38	13	74 (5)	165	30	3/8"	-
SH 10	1000	790	8	38	11	50 (4)	175	40	3/8"	-
SH 15	1500	1190	9	43	13	59 (4)	190	50	1/2"	1/4"
SH 20	2000	1560	10	34	11	53 (4)	200	50	1/2"	1/4"
SH 25	2500	1950	12	29	12	54 (4)	205	50	1/2"	1/4"
SH 34	3400	2680	14	47	15	72 (4)	205	100	3/4"	1/4"
SH 47	4700	3410	16	36	20	120 (5)	220	100	3/4"	1/4"
SH 57	5700	4410	18	27	22	101 (4)	205	100	3/4"	1/4"
SH 60	6000	4680	18	29	22	99 (4)	200	120	3/4"	1/4"
SH 70	7000	5460	20	25	23	108 (4)	200	120	3/4"	1/4"
SH 85	8500	6670	20	19	28	128 (5)	195	120	1"	1/4"
SH 100	10000	7690	24	17	26	121 (4)	205	120	1"	1/4"

Winch type	Mass kg	D1	D2	L1	L2	L3	W1	W2	H1	H2	Hole Ø
SH 08	40	167	258	174	275	170	295	250	279	133	15
SH 10	41	167	258	174	275	170	295	250	279	133	15
SH 15	71	202	312	187	319	170	315	250	348	175	15
SH 20	71	202	312	187	325	170	315	250	348	175	15
SH 25	95	243	376	191	352	190	405	350	403	195	17
SH 34	167	296	454	242	432	250	426	350	498	245	17
SH 47	258	322	530	321	510	330	610	530	566	271	25
SH 57	296	353	570	360	570	375	630	550	612	292	25
SH 60	350	366	580	360	751	360	-	530	630	295	23
SH 70	415	404	610	378	780	380	640	550	620	315	23
SH 85	430	418	640	430	851	435	694	590	665	345	23
SH 100	700	455	720	444	1008	470	788	670	745	385	23

Sales program

Winches C1

Electric wire rope winches for use in areas where people stay under suspended load. (German safety regulations BGV C1). Typical applications are those as lifting of candleholders, advertising material, scenery, loudspeakers, covers. Control according to SIL 3 rules - extended security. Type examination test by technical control authority both for winch and control. Low noise operation. Wall or console mounting, special versions on request.

Standard winch features

- Spur gear transmission drive IP 54 Electric 400 V AC / 3 phases / 50 Hz motor, duty ratio S2 - 10 min.
- Double brake on motor
- Limit switch with 4 contactors
- Drum pressure roller
- Grooved drum
- Coating 2-K acc. to ISO 12944 Kategorie C2-Basis RAL 9005 black
- FEM / ISO class: 2m / M5

Available winch options

- Enlarged drum
- Slack wire switch
- Increased protection class
- Load limit switch

Available control options

- Control box IP 65 with push-buttons and emergency stop built acc. to DIN EN 60204 - 32
- Control box IP 65 with low voltage IP 65 remote control built acc. to DIN EN 60204 - 32
- Radio control according to SIL 3

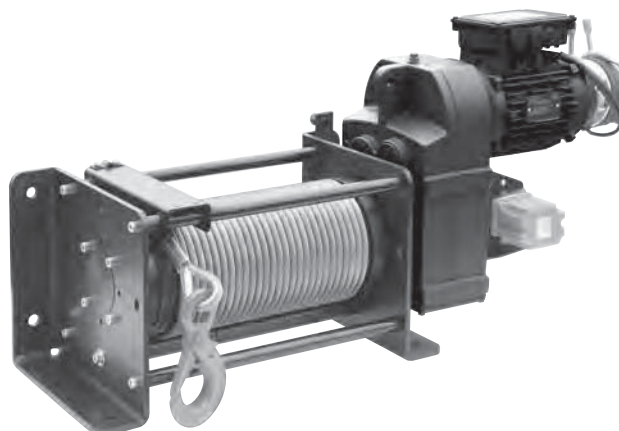

Winch type C1 Electric	Order no.	WLL 1st Layer kg	Recommend. Rope Ø mm	Speed (I) 1st Layer m/min.	Power 400 VAC kW	Speed (II) 1st Layer m/min.	Power 400 VAC kW	Storage 1st Layer m
C1 160	231377	160	5	5.2	0.25	-	-	15
	231378	160	5	-	-	7.6	0.25	15
C1 300	231379	300	7	5.2	0.37	-	-	15
	231380	300	7	-	-	8	0.55	15
C1 490	231381	490	9	5.1	0,55	-	-	15
	231382	490	9	-	-	4.2	0.75	15
C1 1000	231783	1000	12	4.8	1.1	-	-	15
	231784	1000	12	-	-	8.5	2.2	15

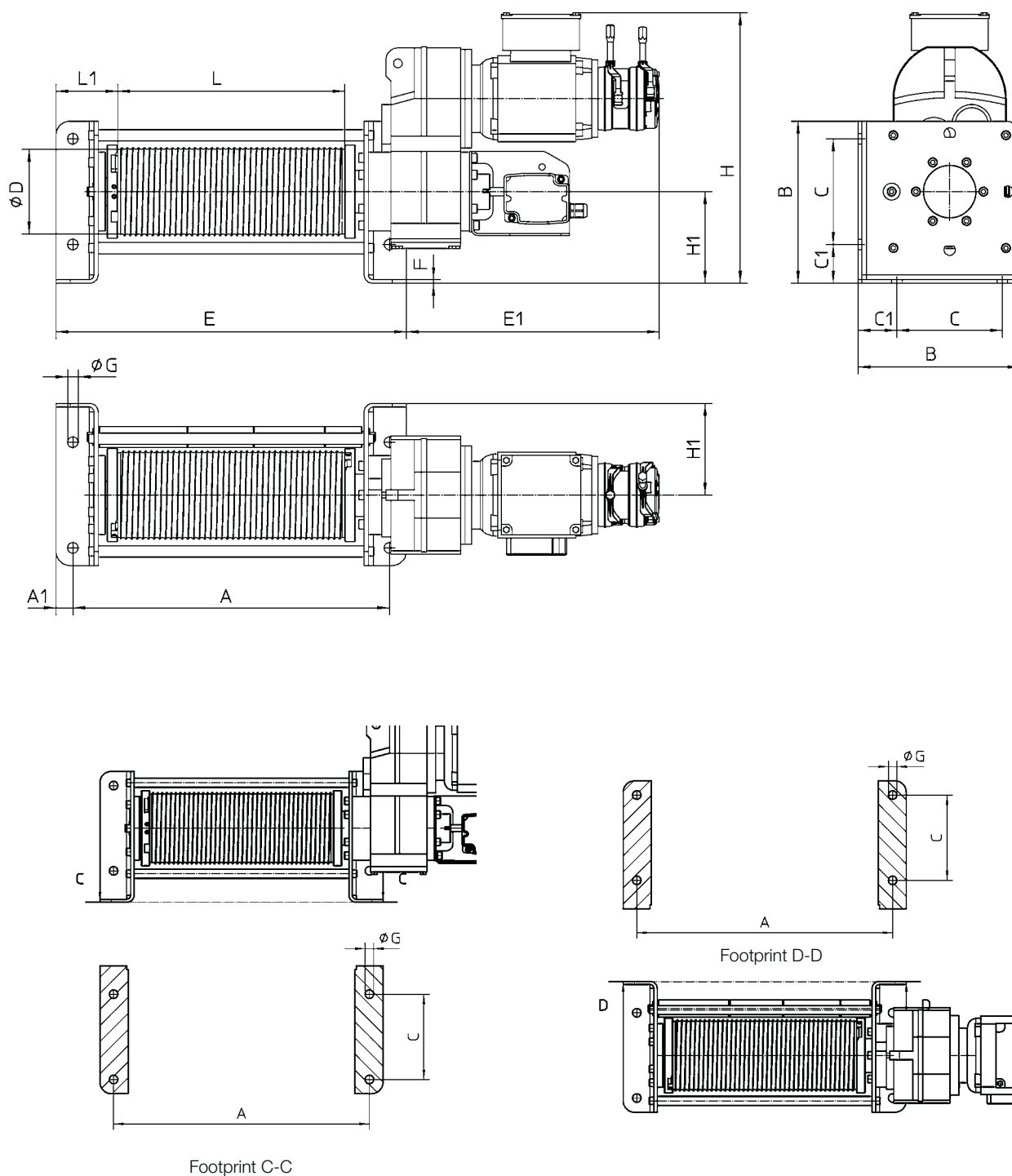

Dim.	A	A1	B	C	C1	D	E	E1	F	G	H	H1	L	L1
C1 160	450	20	200	120	20	85	490	345	5	13	352	120	347	74
C1 300	450	24	230	150	25	120	498	360	5	15	384	130	323	87,5
C1 490	470	30	270	180	30	153	530	403	7	15	438	150	331	100
C1 1000	560	40	360	240	80	206	640	519	9	21	600	200	370	135

Sales program

Personnel lifting winches

Personnel lifting winches are mainly built to client specifications and can be executed with a self-braking worm-, helical- or planetary gear depending on the load required. The drive can be either electric, hydraulic or pneumatic. haacon has supplied manriding systems up to a working load limit of 10,000 kg.

haacon have supplied winches for the following applications:

- Safety harness or a boatswain's chairs
- Diving frame applications
- Baskets or platforms
- Cable way rescue winches

As safety is most important with personnel lifting applications a third party design review is often required. The type of design review is however very much depending on the local rules and regulations. For onshore personnel lifting applications within the European Union often a EC type examination is required. Offshore personnel lifting winches often require the same class as the ship or rig they are being used on. Most common classifications for offshore personnel lifting winches are LRS, ABS, DNV and GL.

All the above classification agencies have different rules and regulations. Therefore it's very important that we are informed about the required classification in order to offer the correct winch to you. Furthermore details about the application are required to determine the required technical specifications.

Prices and drawings are available upon request. Please let us have your specifications.

Standard features

- Selfbraking worm, helical or planetary gear transmissions
- Electric 400 V AC / 3phases / 50 Hz motor.
- Hydraulic orbit, radial piston or axial piston motors
- Pneumatic gear or radial piston motors
- Primary brake on motor
- Secondary brake on winch drum
- Full material traceability (3.1 – EN 10204) on structural steel components
- Two drum supports
- Double layer 2component conservation according ISO 12944 category C2Low, colour RAL 5010 (gentian blue)

Available control options

- electric /hydraulic or pneumatic control systems
- Limit switches
- Slack wire witches
- Overload protection
- Emergency hand crank

Available options

- Explosionproof motors
- Protective steel motor cover
- Drum pressure roller
- Drum guard
- Marine / offshore coating systems
- Spooling gear
- Grooved drum
- Split drums / additional rope anchors / etc.
- Third party design review (LRS, ABS, DNV, etc)

Personnel lifting winches references

MR 30 FLG



150 KG DEDICATED PNEUMATIC MANRIDING WINCH. FOR OFFSHORE APPLICATIONS SUPPLIED WITH LRS, ABS, DNV DESIGN APPROVAL. FOR ONSHORE APPLICATIONS SUPPLIED WITH CE TYPE EXAMINATION CERTIFICATE.

SB 307/185 EVSP

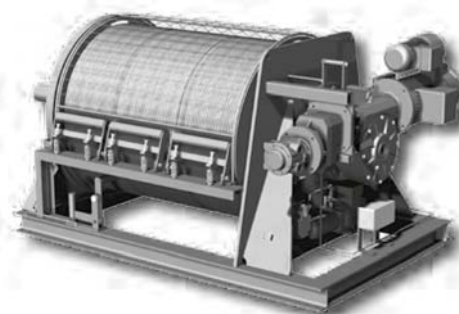

650 KG EEXD ELECTRIC PERSONAL BASKET WINCH FOR GASHOLDER (POSCO, SAARSTAHL, ARCELOR) SUPPLIED WITH EC TYPE EXAMINATION CERTIFICATE

OHR 3.0 BD

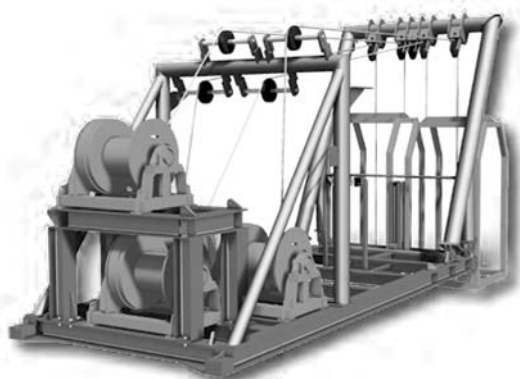

3 TON HYDRAULIC DIVING BELL AND CLUMP WEIGHT WINCH WITH LRS DESIGN APPROVAL.

OHR 3.0 BDGP

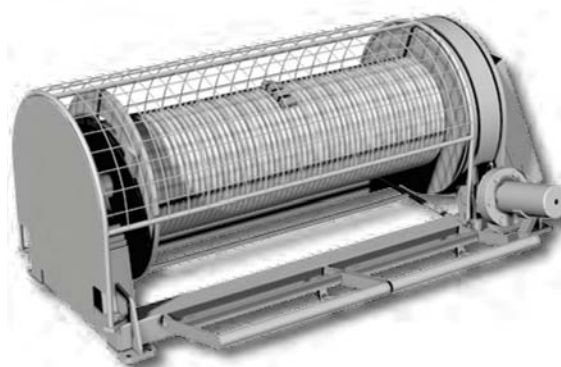

3 TON HYDRAULIC PERSONAL LIFTING WINCH FOR MAINTENANCE BASKET. SUPPLIED WITH DNV DESIGN APPROVAL AND CE TYPE EXAMINATION CERTIFICATE

SB315R HBDGL

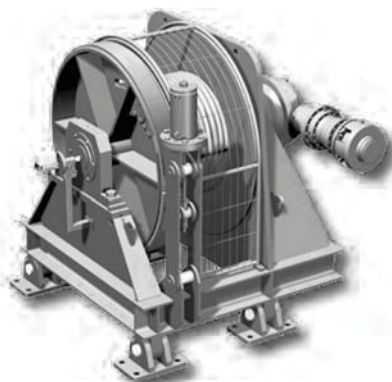

11,5 TON HYDRAULIC DIVING BELL WINCH WITH GL DESIGN APPROVAL

OMR 3.0 LPR6 BD

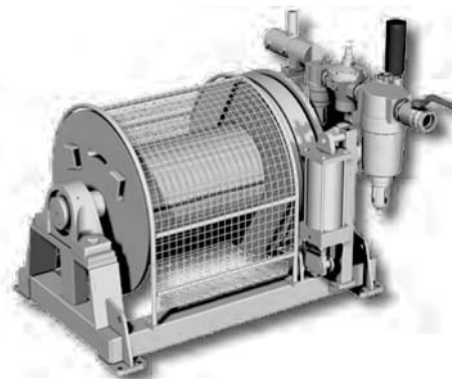

3 TON PNEUMATIC DIVING BELL AND CLUMP WEIGHT WINCH WITH LRS DESIGN APPROVAL

Sales program

Traction winches TR

Traction winches are mainly built for purpose. Winches are built to order and can be executed with a self-braking wormgear or planetary gear depending on the load required. The drive can be either electric, hydraulic or pneumatic. The winches are mainly used for traversing applications where a compact but heavy duty system is required. haacon has supplied systems up to and including 10,000 kg. We have supplied solutions for the following opening and closing of hangar doors, moving railcars along a track, deep sea research and moving trolleys on a cable or at ground. Systems can be supplied with endless cables or with a separate wire spooling unit.

Prices and drawings are available upon request. Please let us have your specifications.

Standard features

- Selfbraking wormgear or planetary gear transmissions
- IP 54 400 V AC / 3phases / 50 Hz non
- braked motor. (440 / 3 / 60)
- Steel sheaves
- Double layer 2component conservation according ISO 12944 category C2Low, colour RAL 5010 (gentian blue)

Available options

- Braked motor (aluminium or cast iron)
- IP 56 TENV cast iron motor for marine applications
- 220 singlephase motors (up to 1.5 kW)
- Explosionproof motors
- Protective steel motor cover
- Manual or remotely controlled disengaging clutch
- Alternative speeds
- Protective guards
- Marine / offshore coating systems

Available control options

- Direct pendant remote control IP 65 with emergency stop (up to 1.5 kW 220 V AC / 1phase or 2.2 kW 400 V AC / 3phases)
- Control box IP 55 with pushbuttons and emergency stop
- Control box IP 66 with low voltage IP 65 remote control
- Load limiter
- Frequency inverter for variable speed control
- Wireless radio remote control systems
- Limit switches

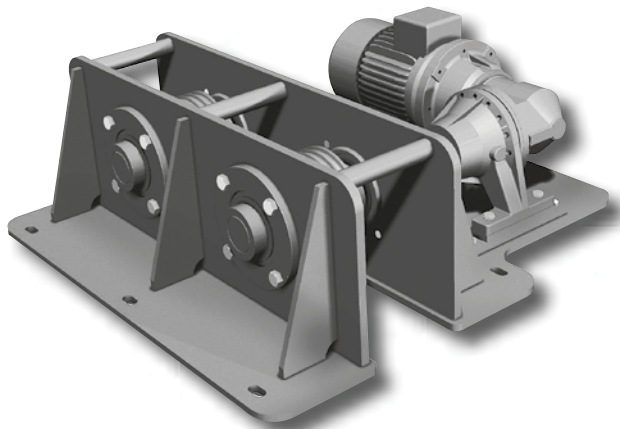

Planetary traction winch

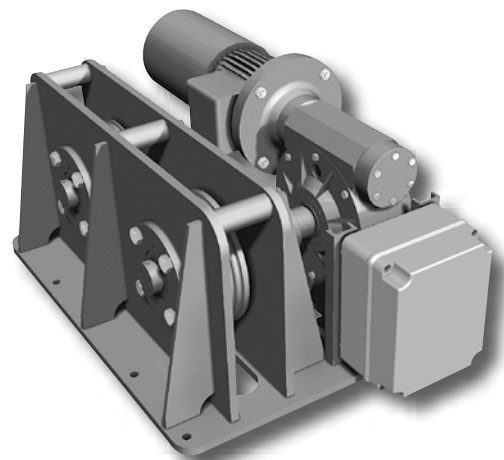

Wormgear traction winch

Mooring winches SRM

This standard range of the SRM type mooring / anchor winches is designed for application on jack-up rigs, barges and other offshore or marine units. These standard winches can be fitted with several options such as free spooling clutches and spooling gears. Also a range of mooring accessories can be offered with these winches such as fairleads, sheaves, wire rope and load measuring equipment. Winches will be subject to our standard internal test procedure, which can be witnessed by the client and / or third party.

Standard winch features

- Heavy duty slew ring
- Heavy duty planetary gearboxes fitted with pinions
- SRM E; IP 56 TENV seawater-resistant 400-440 V AC / 3-phases / 50 - 60 Hz braked motors
- SRM H; radial piston type hydraulic motors complete with brake valve
- Smooth drum
- Band brake (manual)
- Two drum supports
- Lifting lugs
- Three layer 2-component conservation according ISO 12944 category C4-High, colour RAL 1023
- FEM / ISO class: 1A_m / M4

Available control options

- Control box IP 55 with push-buttons and emergency stop
- Control box IP 66 with low voltage IP 65 remote control
- Load limiter
- Frequency inverter for variable speed control
- Load and/or line monitoring
- Proportional local or remote control valve (pneumatic or hydraulic)

Available mooring equipment

- Horizontal deck sheaves without or with load pins
- Swivel fairleads
- 4, 6, 7 or 10 roller fairleads
- Deck bollards and chocks

Available winch options

- Automatic band brakes
- Alternative speeds
- Alternative supply voltages
- Drum guards
- Spooling gears
- Grooved drums
- Alternative drum dimensions / rope lengths / rope diameters
- Warping head
- Wire rope

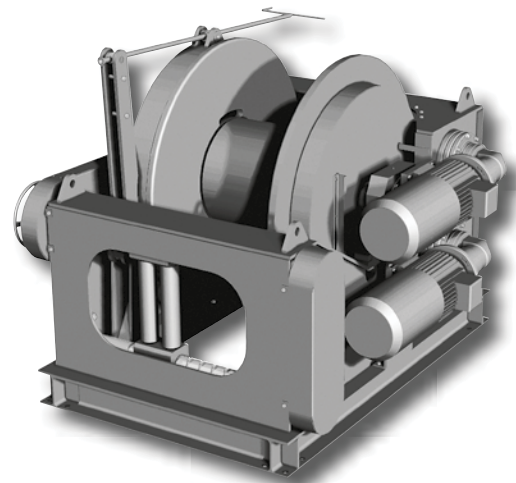

SRM 25 E2

Winch type	WLL 1 ST layer kg	WLL 7 TH layer kg	Recomm. rope diam. mm	Speed 1 ST layer m/min.	Speed 7 TH layer m/min.	Drumcap. 7 TH layer m	Bandbrake holdingforce 1 ST layer / kg	Pressure drop in bar	Flow in l/min.	Motor power kW
SRM 18 E1	18000	11265	32	8.5	13.5	430	45000	-	-	30
SRM 25 E2	25000	14980	36	8.5	14	390	62500	-	-	44
SRM 30 E2	30000	17610	38	7	12	375	75000	-	-	44
SRM 36 E2	36000	22265	44	7.5	12	415	90000	-	-	60
SRM 18 H1	18000	11265	32	8	13	430	45000	220	120	-
SRM 25 H2	25000	14980	36	11	18	390	62500	230	210	-
SRM 30 H2	30000	17610	38	10	17	375	75000	220	240	-
SRM 36 H2	36000	22265	44	8.5	14	415	90000	230	240	-

Sales program

Windlasses W/P/PW

This series of windlasses has been especially designed for intensive use and therefore has a robust construction. All windlasses are designed with a self-braking gearbox (except P 1000 H and P 1600 H) which will save the costs of an expensive brake motor.

The band brakes are lined with a ferrodo (non-asbestos) friction material.

Standard features

- Heavy duty worm gearbox or planetary/ worm gear combination
- IP 56 TENV cast iron 400 V AC / 3 phases / 50 Hz non-braking motor with torque knob
- Orbit type hydraulic motor
- Suitable for 10 – 28 mm DIN / Studlink chain sizes from 12.5 – 28 mm
- Free-fall clutch
- Band brake
- Horizontal cast iron warping head
- Three layer 2-component conservation according ISO 12944 category C4-High, colour RAL 5010 (gentian blue)

Available options

- Double executions possible for W 120 up to W 600
- Alternative supply voltages
- Full manual control by means of hand wheel
- Horizontal warping head configuration
- Remotely controlled band brakes
- Classification certificate from any recognised marine classification body
- Special marine / offshore coating systems

Available control options

- IP 66 control box with IP 65 pendant remote control or push-buttons
- Proportional local or remote control valve

Winch type	Chain pull kg	Chain size din	Chain size stud	Speed m/min.	Bandbrake holding force kg	Motor power 400 V kW S2	Peak power 400 V kW
W 120 E	400	10	-	10	1200	1.1	1.5
W 150 E	600	10-13	-	10	1500	1.5	2.2
W 250 E	750	13-16	14	10	2500	2.2	3
W 350 E	1200	16	16	10	3500	4	5.5
W 400 E	1200	16	16	10	4000	4	5.5
W 600 E	2000	16-18	16	10	6000	5.5	7.5
PW 1000 E	3600	20	19	10	10000	7.5	11
PW 1600 E	5500	22	22	10	16000	15	18.5
Winch type	Chain pull kg	Chain size din	Chain size stud	Speed m/min.	Bandbrake holding force kg	Pressure drop in bar	Flow in l/min.
W 120 H	400	10	-	10	1200	70	20
W 150 H	600	10-13	-	10	1500	100	20
W 250 H	750	13-16	14	10	2500	60	40
W 350 H	1200	16	16	10	3500	95	40
W 400 H	1200	16	16	10	4000	95	40
W 600 H	2000	16-18	16	10	6000	100	60
P 1000 H	3600	20	19	10	10000	95	55
P 1600 H	5500	22	22	10	16000	120	60

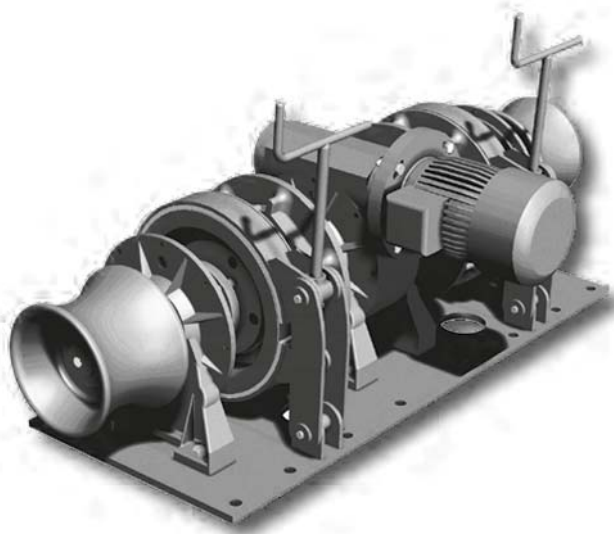
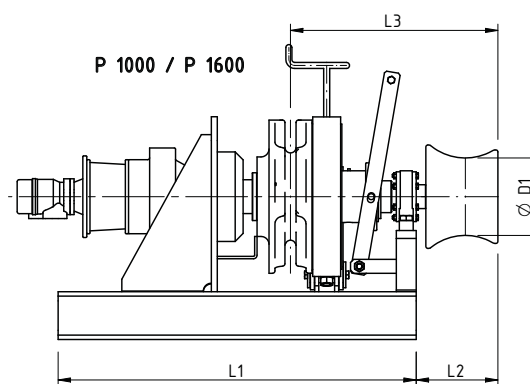
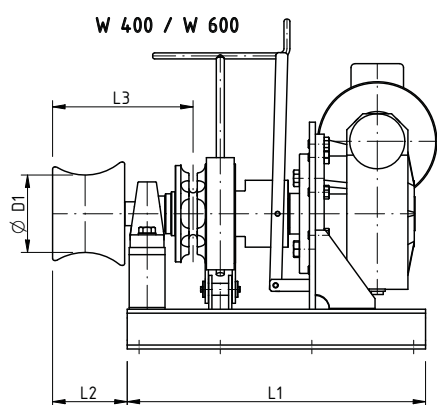
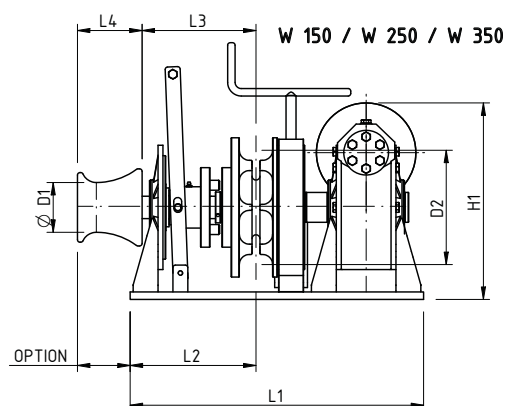
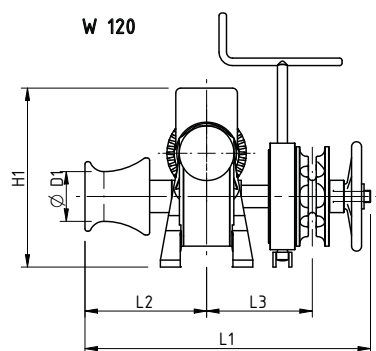

Type	Mass kg	D1	D2	L1	L2	L3	L4	H1
W 120	63	100	180	590	255	245	130	295
W 150	140	100	180	590	250	245	130	295
W 250	170	140	190	650	290	280	130	340
W 350	260	195	255	700	305	295	181	385
W 400	240	195	-	700	180	440	-	-
W 600	500	195	-	750	180	460	-	-
P 1000	360	280	-	1300	210	560	-	-
P 1600	500	280	-	1500	210	600	-	-

Sales program

Capstans C

WORMGEAR CAPSTANS

Self-braking worm gear drives with electric, hydraulic or even pneumatic motor, available in on-deck or below-deck build types. The on-deck drive is equipped with a waterproof motor for intermittent use. The below-deck drive is equipped with a dripwater-proof motor and a mounting plate with an extra self aligning bearing suitable for high static loads such as with mooring ropes. Pneumatic drives are available upon request.

PLANETARY CAPSTANS

Featuring a cast iron capstan head mounted on a heavy duty planetary gearbox. The entire drive is mounted in a watertight tube frame providing optimal protection from the elements. Pneumatic drives are available upon request. Capstans up to 15 tons can be offered upon request.

Standard features

- Heavy duty wormgear or planetary gearbox
- IP 54 braked motor 400 VAC / 3-phases / 50 Hz for planetary capstans
- IP 56 TENV cast iron 400 V AC / 3-phase / 50 Hz non-braked motor for on-deck wormgear capstans
- IP 54 400 V AC / 3 phases / 50 Hz non-braked motor for under-deck wormgear capstans
- Single speed and one direction only (electric capstans only)
- Orbit or radial piston type hydraulic motor
- Vertical cast iron warping head according to ISO 6482
- Three layer 2-component conservation according ISO 12944 category C4-High, colour RAL 5010 (gentian blue)

Available options

- Cast iron motor for planetary capstans
- Explosion proof motors
- Back stop bearing build in planetary gearbox for one direction (replaces brake)
- 2 speed motors
- Alternative speeds
- Alternative supply voltages
- Horizontal warping head configuration
- Marine / offshore coating systems

Available control options

- Control box IP 55 with IP 65 foot pedal (single speed, one direction) control
- Control box IP 66 with IP 66 foot pedal (two speed, two directions) control
- Frequency inverter and proportional foot pedal for variable speed control
- Proportional local or remote control valve (pneumatic or hydraulic)

Winch type Worm	WLL kg	Speed m/min	Neck diameter mm	Max. rope diam. mm	Motor power 400 V kW	Pressure drop in bar	Flow in l/min.
C 086 E	500	6	100	16	1.1	-	-
C 110 E	700	11	140	22	2.2	-	-
C 130 E	1100	9	140	22	3	-	-
C 150 E	1300	13	195	30	5.5	-	-
C 185 E	1700	10	195	30	5.5	-	-
C 086 H	500	8	100	16	-	70	20
C 110 H	700	8	140	22	-	105	15
C 130 H	1100	7	140	22	-	60	40
C 150 H	1300	10	195	30	-	90	40
C 185 H	1800	10	195	30	-	90	60

Winch type Planetary	WLL continuous kg	Speed m/min.	Neck diameter mm	Recomm. rope diam. mm	Motor power 400 V Kw	Pressure Drop in Bar	Flow in l/min.
C 300 E	1000	12	195	30	2.2	-	-
C301 E	1650	10	195	30	3	-	-
C 303 E	2300	10	195	30	4	-	-
C 305 E	3400	9	275	35	5.5	-	-
C 307 E	5500	11	405	52	11	-	-
C 309 E	7500	11	405	52	15	-	-
C 310 E	10000	8	450	75	15	-	-
C 300 H	1000	30	195	30	-	105	60
C 301 H	1650	28	195	30	-	135	60
C 303 H	2600	18	195	30	-	140	60
C 305 H	4000	17	275	35	-	165	70
C 307 H	6000	25	405	52	-	220	105
C 309 H	7500	20	405	52	-	205	120
C 310 H	10000	17	450	75	-	230	120

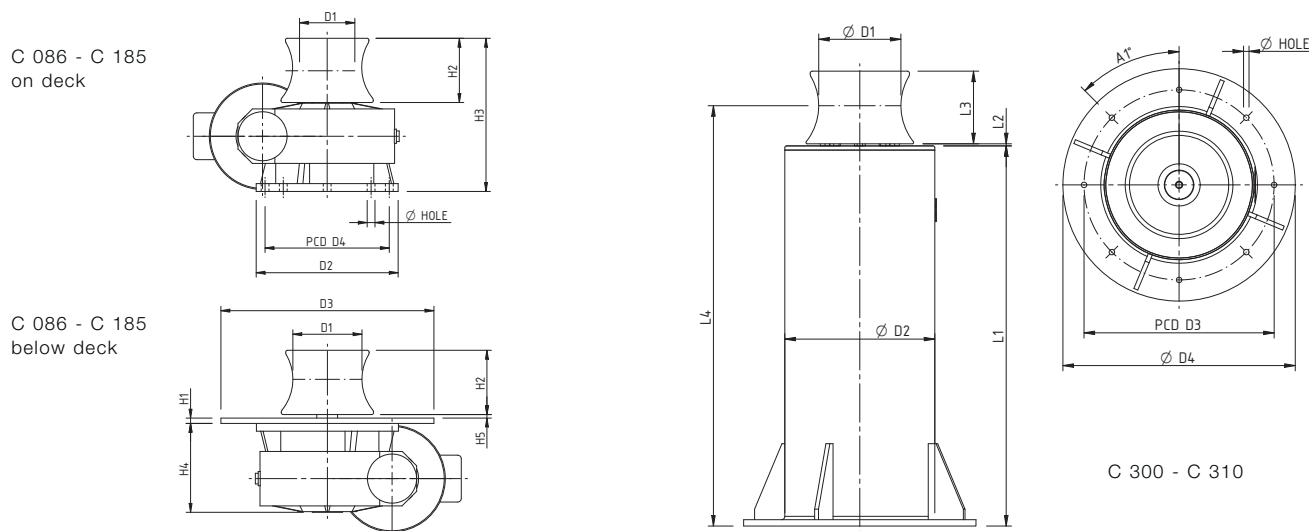

Type	Mass kg	D1	D2	D3	D4	H1	H2	H3	H4	H5	Hole
C 086	50	100	210	300	176	10	130	320	190	10	8x 12.5
C 110	70	140	280	390	230	10	130	350	209	10	8x 13.5
C 130	90	140	320	420	255	15	130	360	230	10	8x 16
C 150	130	195	350	450	290	15	180	415	245	10	8x 18
C 185	170	195	400	500	350	15	180	440	251	10	8x 22
Type	Mass kg	D1	D2	D3	D4	L1	L2	L3	L4	A1	Hole
C 300	225	195	355	450	550	900	5	181	1004	8x 45	13
C 301	225	195	355	450	550	900	5	181	1004	8x 45	13
C 303	275	195	406	500	600	1000	5	181	1104	12x 30	18
C 305	405	275	455	570	650	1100	5	255	1246	12x 30	18
C 307	870	405	610	700	800	1300	5	320	1487	12x 30	18
C 309	930	405	610	720	825	1300	5	320	1487	12x 30	22
C 310	1095	450	711	840	950	1350	5	500	1636	10x 36	27

Sales program

Accommodation Ladder winches AW/PW

AW winches are designed to position and hold accommodation and ship-to-shore ladders and ladders between vessels and offshore installations.

Constructed in accordance with SOLAS (Safety of Life at Sea) requirements for international shipping, the range features a dynamically and statically self-braking wormgear and emergency hand crank. Each type may be configured for single or twin rope operation and powered by means of an electric or pneumatic motor.

PW winches are used to lower and lift the pilot ladder on board of seagoing vessels, haacon has one standard design, PW 550, that has been supplied to several dredging vessel fleet owners. We have also supplied custom-built designs. Please ask about the available options.

Standard features

- Self-braking wormgear transmission for the AW series
- Planetary gear for PW 550
- SOLAS compliance
- IP 56 TENV motor protection for the AW ES series
- IP 66 TENV with standstill heating for the PW 550
- Rotary vane, gear type air or motor for the AW LS series
- Steel drum (not grooved) with one or two cable fixing point(s) at flange
- Two drum supports
- Emergency hand crank for the AW series only
- Double layer 2-component conservation, colour RAL 5010 (gentian blue)
- 13 meter pilot ladder with 32 flat steps, 4 spreaders and 4 rubber steps for PW 550
- Pneumatic versions with hand control valve
- IP 66 spindle limit switch for PW 550
- FEM / ISO class: 1Am / M4

Available options

- Band brake, manual or automatic fail-safe for the AW series
- Increased motor protection IP 68 TENV for the AW series
- Alternative supply voltages
- Grooved drum for AW series only
- Drum pressure roller for AW series only
- Alternative speeds
- Alternative drum dimensions / split drums / additional rope anchors / etc.
- Drum guard for AW series only
- Marine / offshore coating systems
- Class witness certificates

Available control options

- Electric or pneumatic control systems
- Limit switches
- Load limiters

Winch type	WLL kg	Holding Force kg	Recomm. Rope diam. mm.	Speed 1 st layer m/min.	Drumcap. 3 rd layer m	Motor power 400 VAC kW	Pressure Drop bar	Flow in l/s
AW 500 ES	500 2 X 250	1500 1500	8 6	6 6	30 2 X 18	1.5 1.5	-	-
AW 1000 ES	1000 2 X 500	3000 3000	10 8	7.5 7.5	40 2 X 23	3 3	-	-
AW 1500 ES	1500 2 X 750	4000 4000	12 10	9.5 9.5	50 2 X 27	5.5 5.5	-	-
AW 500 LS	500 2 X 250	1500 1500	8 6	6 6	30 2 X 18	-	6 6	60 60
AW 1000 LS	1000 2 X 500	3000 3000	10 8	6.5 6.5	40 2 X 23	-	6 6	100 100
AW 1500 LS	1500 2 X 750	4000 4000	12 10	7.5 7.5	50 2 X 27	-	6 6	130 130
PW 550 E	550	2000	-	12	13 m ladder	1.1	-	-

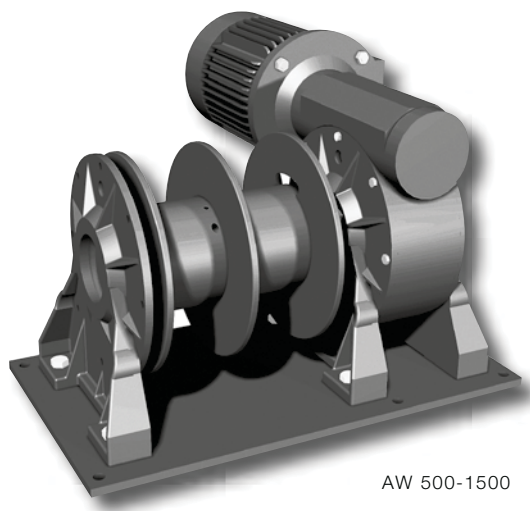
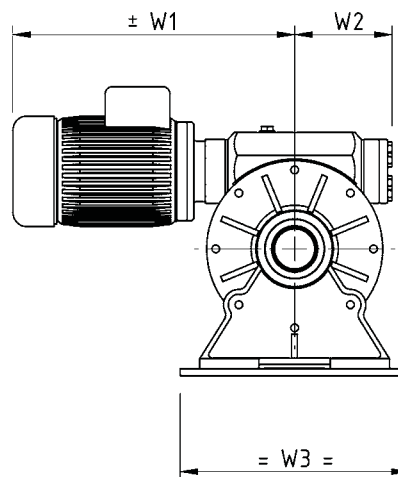
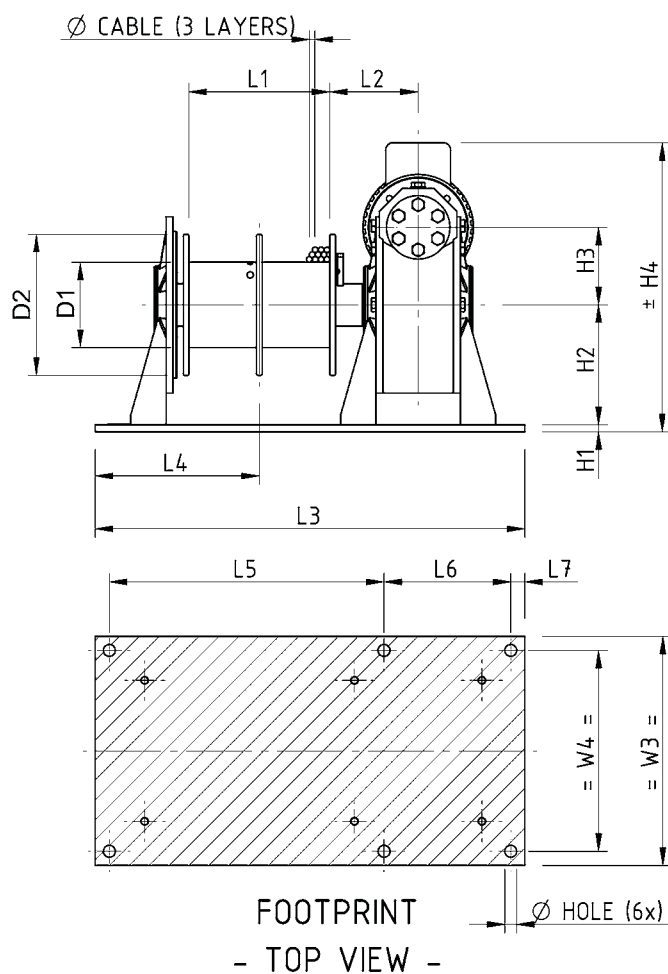

AW 500-1500

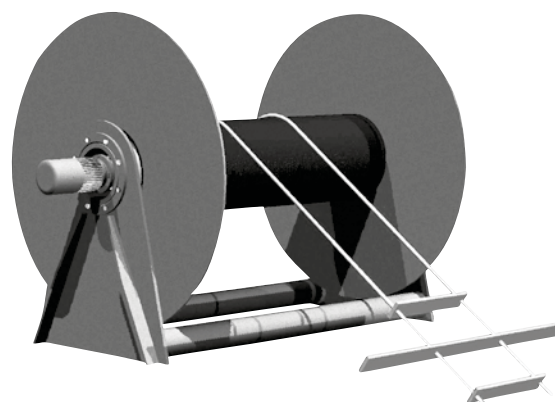

PW 550

Type	Mass kg	D1	D2	L1	L2	L3	L4	L5	L6	L7	H1	H2	H3	H4	W1	W2	W3	W4	Hole \varnothing
AW 500	85	121	250	200	125.5	610	228	390	180	20	10	170	110	410	400	140	325	285	17
AW 1000	195	159	320	250	155	710	260	470	200	20	15	220	150	522	519	154	410	360	17
AW 1500	275	195	370	300	180	850	318	565	235	25	15	254	182	570.5	546	207	440	380	20
PW 550	1600	508	1700	1900	218	2440	1193	2552	-	-	-	1080	-	1930	650	250	-	-	-

Sales program

Hose reel / Umbilical / Transponder winches HR/UR/TW

Hose reel, umbilical or transponder winches are mainly built for purpose. Winches are built to order and can be executed with a self-braking wormgear or planetary gear, depending on the load required. The drive can be either electric, hydraulic or pneumatic.

The hose reels are mainly used to reel hoses for fresh water supply, MDO (Marine Diesel Oil) fuel supply and hydraulic oil or to reel electrical power supply cables.

The umbilical winches are, generally, used to reel a combination of hoses, signal cables, coax or even fibre optic cables. Most of them come with slip rings and/or rotating swivels.

Transponder winches used for powered transponders are mainly used with electrical signal cables and have, in most cases, an electrical slip ring mounted. Winches can be supplied complete with an A-frame if required.

haacon has supplied systems for all applications including reels with 6" stainless steel swivels or slip rings for high voltage.

The versions we have supplied can be found on the following type of constructions: offshore heavy lift vessels, offshore semi-sub, diving support vessels, research vessels, cable and pipe laying vessels and offshore pile-driving barges.

Standard features:

- Self-braking wormgear, helical bevel, planetary or slew gear transmissions
- IP 56 TENV 400 V AC / 3 phases / 50 Hz braked motors (or 440/3/60)
- Radial piston air or hydraulic motors
- Heavy duty construction
- Double layer 2-component conservation according ISO 12944 category C2-Low, colour RAL 5010

Available control options:

- Control box IP 55 with push-buttons and emergency stop
- Control box IP 66 with low-voltage IP 65 remote control
- Load limiters
- Frequency inverters for variable speed control
- Wireless radio remote control systems
- Limit switches
- Pneumatic and hydraulic control systems

Available options:

- Explosion-proof electric motors
- Protective steel motor covers
- Alternative speeds
- Protective guards
- Stainless steel slip rings (fibre optic or elec.)
- Stainless steel swivels
- Spooling devices



Umbilical winch



Hose reel

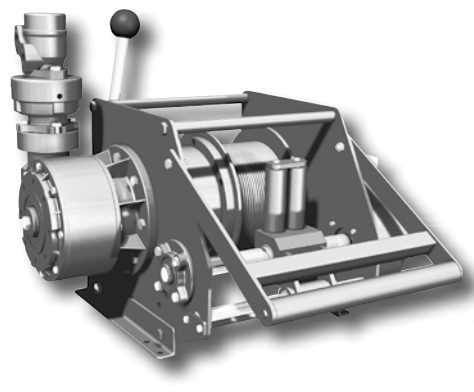

Transponder winch

Application sheet

Fax to 0049 (0) 9375- 8486

or via e-mail to hebetechnik@haacon.de

A completable online form is available on:

http://www.haacon.de/media/checklisten/checkliste_angetr_Seilwinden_en.pdf

Company Date.....
 Street..... Phone.....
 PO Box Fax
 Official in charge..... Email

Pieces.....

REQUIREMENTS:

- Hoisting (vertical)kg
- Pulling (horizontal)kg
- Rope capacitym
- Line speedm/min
- BGV D8¹ BGV C1²
- Temperature °C

MOTOR:

- Electric
- 400 V - AC 230 V - AC 24 V - DC
- Protection IP..... Duty ratio.....
- Indoor use
- Outdoor use

- Hydraulic
- Pressure..... bar
- Flow ratel/min.
- Pneumatic
- Air pressure..... bar
- Air capacityl/s

OPTION:

- Limit switch
- Slack wire switch
- Load limiter
- Disengager/clutch (applicable for pulling winches only)
- Pressure roller
- Grooved drum
- Devided drum
- others

CONTROLS:

- Pendant remote control
- Control box with push-buttons
- Radio remote control
- others

PAINTING:

- Standard RAL 5010 gentian blue
- Special RAL-N° .:

Documentation/Type plate

- english
- german
- french
- others

Application:

.....

.....

.....

.....

¹ German Accident Prevention Regulations (BG) for winches, lifting- and pulling equipment

² German Accident Prevention Regulations (BG) for event areas, studios and scenes

Sales program

Example for approval drawing

<p>3.1 FOR APPROVAL FOR APPROVAL 23-3-2007</p> <p>GENERAL NOTES: 1. DIMENSIONS ARE IN MILLIMETERS UNLESS OTHERWISE SPECIFIED. 2. ALL DIMENSIONS ARE TO CENTER UNLESS OTHERWISE SPECIFIED.</p>	<p>FOR APPROVAL DATE: <u> </u> SIGNED: <u> </u> (Signature)</p>																																																
<p>TECHNICAL DATA:</p> <table border="1"> <tr><th colspan="4">SAFETY</th></tr> <tr><td>Weight</td><td>1500 kg</td><td>Capacity</td><td>3000 kg</td></tr> <tr><td>Max. Lifting Speed</td><td>1.5 m/min</td><td>Max. Hoist</td><td>200 m</td></tr> <tr><td>Max. Cable Length</td><td>200 m</td><td>Max. Cable Dia.</td><td>30 mm</td></tr> <tr><td>Max. Cable Weight</td><td>100 kg</td><td>Max. Cable Tension</td><td>200 kN</td></tr> <tr><td>Max. Cable Tension</td><td>200 kN</td><td>Max. Cable Dia.</td><td>30 mm</td></tr> <tr><td>Max. Cable Weight</td><td>100 kg</td><td>Max. Cable Tension</td><td>200 kN</td></tr> <tr><td>Max. Cable Dia.</td><td>30 mm</td><td>Max. Cable Tension</td><td>200 kN</td></tr> <tr><td>Max. Cable Weight</td><td>100 kg</td><td>Max. Cable Tension</td><td>200 kN</td></tr> <tr><td>Max. Cable Dia.</td><td>30 mm</td><td>Max. Cable Tension</td><td>200 kN</td></tr> <tr><td>Max. Cable Weight</td><td>100 kg</td><td>Max. Cable Tension</td><td>200 kN</td></tr> <tr><td>Max. Cable Dia.</td><td>30 mm</td><td>Max. Cable Tension</td><td>200 kN</td></tr> </table> <p>GENERAL DATA:</p> <p>1. DIMENSIONS ARE IN MILLIMETERS UNLESS OTHERWISE SPECIFIED. 2. ALL DIMENSIONS ARE TO CENTER UNLESS OTHERWISE SPECIFIED.</p>	SAFETY				Weight	1500 kg	Capacity	3000 kg	Max. Lifting Speed	1.5 m/min	Max. Hoist	200 m	Max. Cable Length	200 m	Max. Cable Dia.	30 mm	Max. Cable Weight	100 kg	Max. Cable Tension	200 kN	Max. Cable Tension	200 kN	Max. Cable Dia.	30 mm	Max. Cable Weight	100 kg	Max. Cable Tension	200 kN	Max. Cable Dia.	30 mm	Max. Cable Tension	200 kN	Max. Cable Weight	100 kg	Max. Cable Tension	200 kN	Max. Cable Dia.	30 mm	Max. Cable Tension	200 kN	Max. Cable Weight	100 kg	Max. Cable Tension	200 kN	Max. Cable Dia.	30 mm	Max. Cable Tension	200 kN	
SAFETY																																																	
Weight	1500 kg	Capacity	3000 kg																																														
Max. Lifting Speed	1.5 m/min	Max. Hoist	200 m																																														
Max. Cable Length	200 m	Max. Cable Dia.	30 mm																																														
Max. Cable Weight	100 kg	Max. Cable Tension	200 kN																																														
Max. Cable Tension	200 kN	Max. Cable Dia.	30 mm																																														
Max. Cable Weight	100 kg	Max. Cable Tension	200 kN																																														
Max. Cable Dia.	30 mm	Max. Cable Tension	200 kN																																														
Max. Cable Weight	100 kg	Max. Cable Tension	200 kN																																														
Max. Cable Dia.	30 mm	Max. Cable Tension	200 kN																																														
Max. Cable Weight	100 kg	Max. Cable Tension	200 kN																																														
Max. Cable Dia.	30 mm	Max. Cable Tension	200 kN																																														
	<p>SAMSUNG HEAVY INDUSTRIES SB 315 EDS GENERAL ARRANGEMENT MOORING WINCH DATASHEET SAIPEM / SAKHALIN / J-TUBE CABLE PULLING</p>																																																
<p>FOR APPROVAL DATE: <u> </u> SIGNED: <u> </u> (Signature)</p>																																																	
<p>DATE: 23-3-2007 Rev. 1.1 DRAWN: D. Schuiling Scale: A3 Unit: mm CHECKED: 2.060057 Project No.: SB0.0315.01.001 Part: 1 N.T.S.</p>																																																	

References

A 41H ELPS

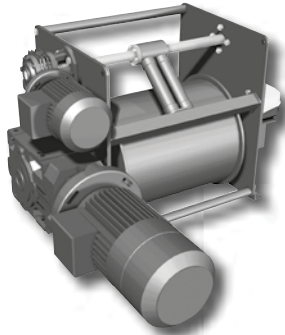
 DP 3 TRANSPONDER WINCH
FOR SEATRUCKS JASCON 5

WRS 2.3 EBC

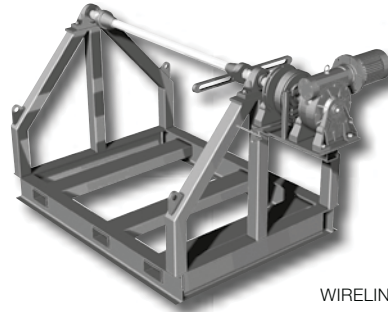
 WIRELINE ROPE SPOOLER
FOR ONGC INDIA

SR 30 H2

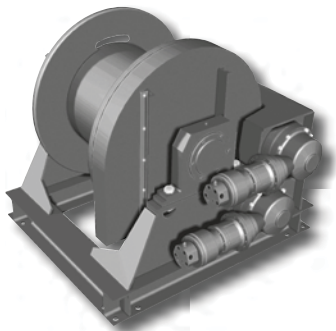
 30 TON HYDRAULIC
WINCH FOR UNOCAL
THAILAND

SB 306 H

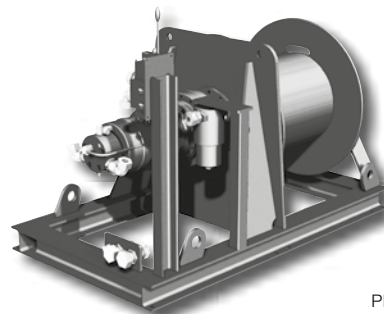
 5 TON HYDRAULIC
PICK-UP WINCH FOR
APL BUOY

OAW 7.5 GP16

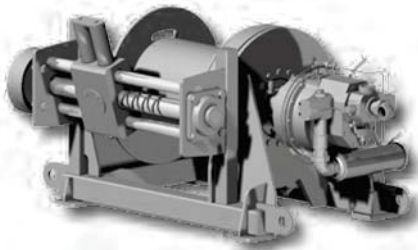
 10 TON PNEUMATIC
WINCH FOR JURONG
SHIPYARD PTE LTD

SR 315R EDS

 30 TON J-TUBE CABLE
PULLING ELECTRIC
WINCH FOR SAMSUNG
(SAKHALIN PROJECT)

OAW 5.0 GP10

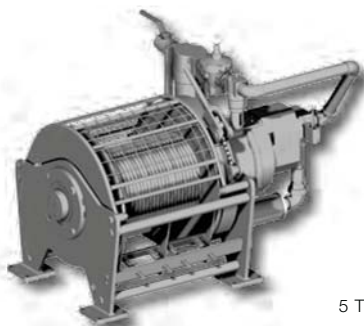
 5 TON PNEUMATIC
WINCH FOR M.I.S. U.A.E.

SB 316R HS

 40 TON DAVIT WINCH
FOR SAS GOUDA

Power

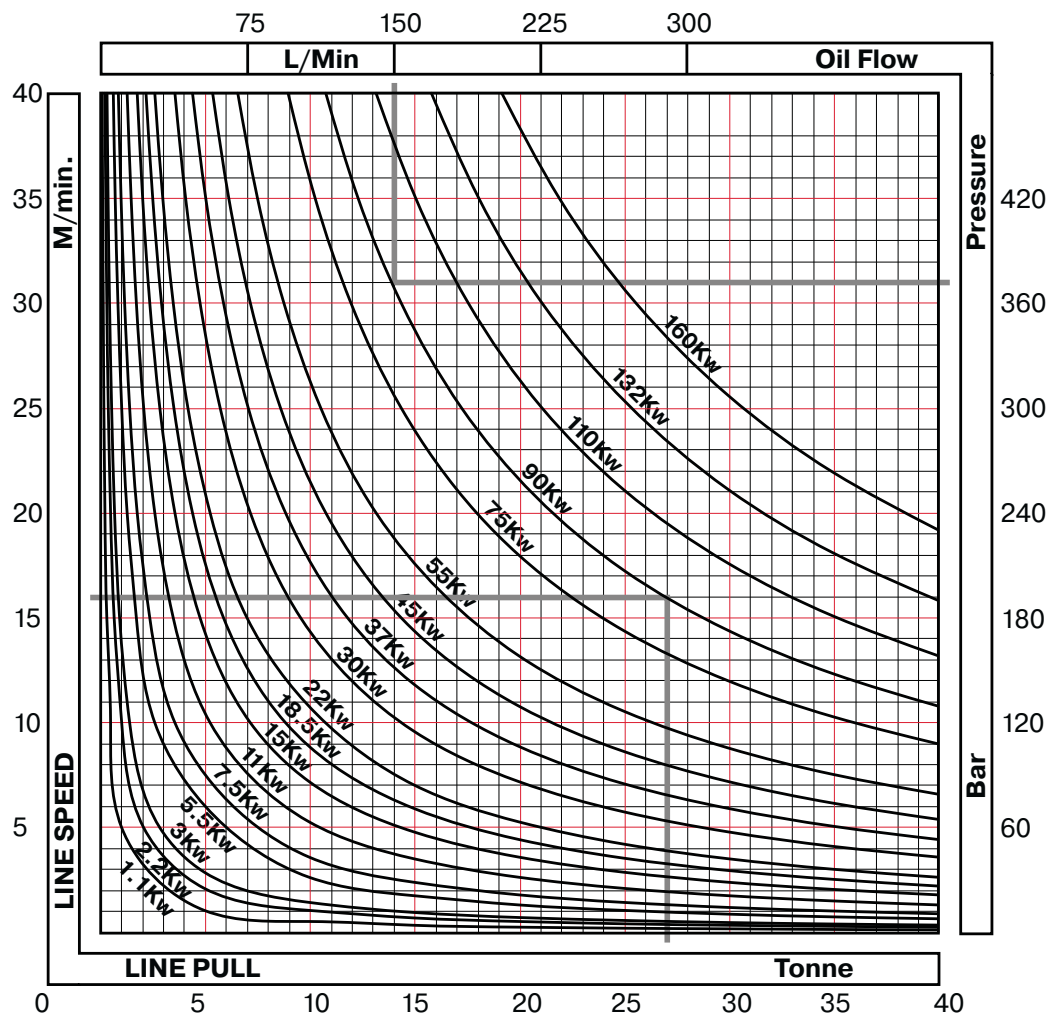

PLANETARY WINCH

Example:

27 tonne pull at 16 m/min speed give 90 kW
90 kW at 186 bar give min. 300 l/min

Air winches

Air pressure 7 bar

Air consumption 21 l/s per kW

Planetary winch total efficiency 80%

Example:

Load (F) 27 Ton, speed (V) 16 meter/min, give 88 kW by calculation.

Installed electric motor will be 90 kW

Hydraulic required, with available 300 liter/min, a pressure of 190 bar is needed. Or; When we only have 150 liter/min. available oil flow, we need to go to a pressure over 360 bar. Please check the available pressure and flow in hydraulic applications and make sure it suits the power chart's requirements.

Power is the ability to deliver a certain performance in a certain time.

Speed (V) and load (F) combined, can be expressed in power (P in kW) by a mathematical formula:

$$P = (V \times F) : 6120$$

P in kW, V in meters/min., F in kg (1 kg ~ 10 Newton), 6120 is constant.

The theoretical value can easily be calculated, but in practice we need to install sufficient power to overcome efficiency losses. Cable on sheaves, cable on drum, gearbox, motor electric or hydraulic and the supply lines all create losses.

To overcome these losses we need to install extra power. In the power chart we already accounted for an average loss, so the power you find in the graph is roughly the installed power.

FEM rating

Once we know;

•What has to be lifted, the load in kg or in Newton (1 kg = 9,81 N.)

•Is the load always the same, or does it vary?
If the load changes we need to know the percentage off load in relation to the percentage in time.

For example:

Max load 500 kg, use 20% off the time.

Average load 400 kg, use 70% off the time.

Minimum load 200 kg, use 10% off the time.

With this "load spectrum" you can work out the Spectrum factor Km.

Once we have worked out the average daily use and load, we can "FEM / ISO - rate" the winch.

TABLE 1 - WINCH „FEM“ CLASSIFICATION

Winch Class Load spectrum	Effective use									
	T0	T1	T2	T3	T4	T5	T6	T7	T8	T9
L1	M1	M1	M1	M2	M3	M4	M5	M6	M7	M8
L2	M1	M1	M2	M3	M4	M5	M6	M7	M8	M8
L3	M1	M2	M3	M4	M5	M6	M7	M8	M8	M8
L4	M2	M3	M4	M4	M6	M7	M8	M8	M8	M8

The formula

$$K_m = ((F_1/F_{max})^3 \times (t_1/T)) + ((F_2/F_{max})^3 \times (t_2/T)) + ((F_3/F_{max})^3 \times (t_3/T)) \text{ etc.}$$

Example:

Winch max load 2000 kg (20 kN)

Winch life request 1000 hours

Winch use 1 hour/day – 10 % time at 1800 kg, 30 % time at 1200 kg, 60% time at 1000 kg

In this example the Km factor (winch use) will be;

$$K_m = ((1800/2000)^3 \times 0,1) + ((1200/2000)^3 \times 0,3) + ((1000/2000)^3 \times 0,6) = 0,21$$

Km = 0,21 (table 3) leads to symbol L2

The use and life-expectancy (table 2) leads to symbol T3

The FEM classification (table 1) leads to symbol M3

The FEM rating for this application is T3-L2 – M3

TABLE 2 - EFFECTIVE USE AND LIFETIME

Symbol	Total effective use (lifetime in hours) „T“	Daily use hours
T0	T < 200	< 0,12
T1	200 < T < 400	< 0,25
T2	400 < T < 800	< 0,5
T3	800 < T < 1600	< 1
T4	1600 < T < 3200	< 2
T5	3200 < T < 6300	< 4
T6	6300 < T < 12500	< 8
T7	12500 < T < 25000	< 12
T8	25000 < T < 50000	< 16
T9	50000 < T	> 16

TABLE 3 - SPECTRUM FACTOR

Symbol	Spectrum factor
L1	Km ≤ 0,125
L2	0,125 < Km ≤ 0,25
L3	0,25 < Km ≤ 0,5
L4	0,5 < Km ≤ 1

From experience we learned that very often the people working with the winch, cannot always give all the details,

they simply want the 5 tons winch, running 10 meters/min.

In that case our catalogue at least provides the information about the "real" winch capacity.

The request sheet (page 4) might help you to get as many as possible answers for a proper selection.

The haacon technical and commercial staff is glad to verify your selection and discuss all possibilities to design and produce your "tailor-made" winch.

Reference ISO- to FEM- Identification										
Effective use and lifetime	FEM	V0,06	V0,12	V0,25	V0,5	V1	V2	V3	V4	V5
	ISO	T0	T1	T2	T3	T4	T5	T6	T7	T8
Load spectrum	FEM	1	2	2	3					
	ISO	L1	L2	L3	L4					
Rating	FEM	1 D _m	1 C _m	1 B _m	1 A _m	2 _m	3 _m	4 _m	5 _m	
	ISO	M1	M2	M3	M4	M5	M6	M7	M8	



haacon

haacon

haacon hebetchnik gmbh
Josef-Haamann-Str. 6
D-97896 Freudenberg/Main
Tel. + 49 (0) 93 75/84-0
Fax + 49 (0) 93 75/84-86
hebetchnik@haacon.de

Regional sales

haacon FRANCE
3 D, rue du Fort
F - 67118 Geispolsheim
Tel. + 33 (0) 3 90 40 30 10
Fax + 33 (0) 3 90 40 30 14
haaconfrance@haacon.com

haacon hebetchnik austria gmbh
Ing. Johannes Haller
Mobil + 43 (0) 664/16 23 91 7
Tel. + 49 (0) 9375/84-321
Fax + 49 (0) 9375/84-86
j.haller@haacon.com

All sales partner addresses are available on www.haacon.de/en/contact.html

Finnhoist

Finnhoist Oy
Bredantie 12 D
02700 Kauniainen
www.finnhoist.fi

roy.soderholm@finnhoist.fi